

# User Manual

## ---- Xtool H6 Pro Diagnosis



# Content

<b>Statement .....</b>	<b>III</b>
<b>1. Overview .....</b>	<b>1</b>
<b>1.1. Introduction .....</b>	<b>1</b>
<b>1.2. Main host .....</b>	<b>1</b>
1.2.1. Appearance .....	1
1.2.2. Parameter .....	2
1.2.3. Power .....	2
<b>1.3. VCI box .....</b>	<b>3</b>
1.3.1. Appearance .....	3
1.3.2. Parameter .....	4
<b>1.4. Accessories .....</b>	<b>4</b>
1.4.1. Main cable .....	4
1.4.2. Vehicle adapters .....	4
1.4.3. Other accessories .....	5
<b>2. Activation .....</b>	<b>6</b>
<b>2.1. Activate process and operation .....</b>	<b>6</b>
<b>2.2. Update first time .....</b>	<b>9</b>
<b>3. Vehicle Connection .....</b>	<b>11</b>
<b>3.1. Connection procedure .....</b>	<b>11</b>
<b>4. Function and diagnosis operation .....</b>	<b>12</b>
<b>4.1. Interface .....</b>	<b>12</b>
4.1.1. Tablet OS Interface .....	12
4.1.2. Xtool Diagnosis APP Interface .....	13
<b>4.2. Setting .....</b>	<b>16</b>
<b>4.3. Diagnosis .....</b>	<b>19</b>
4.3.1. VIN .....	19
4.3.2. Vehicle selection .....	20
4.3.3. Function .....	26
4.3.4. Service .....	33
4.3.5. Operation record and diagnosis report .....	35
<b>4.4. Update .....</b>	<b>38</b>
<b>4.5. Report .....</b>	<b>38</b>
<b>4.6. Xlcloud .....</b>	<b>44</b>
<b>4.7. Remote .....</b>	<b>45</b>
<b>5. Support and service .....</b>	<b>46</b>
<b>5.1. Technical support .....</b>	<b>46</b>
<b>5.2. Service .....</b>	<b>47</b>

---

5.3. *FAQ* ..... 47

6. **Warranty** ..... 49

## Statement

## Trademark

**XTOOL** is the registered trademark of Shenzhen Xtooltech Co., Ltd. In countries that the trademarks, service marks, domain names, logos and the name of the company are not registered, Xtool claims that it still reserves the ownership of the unregistered trademarks, service marks, domain names, logos and the company name. All other marks for the other products and the company's name mentioned in the manual still belong to the original registered company.

## Copyright

You may not use the trademarks, service marks, domain names, logos and company name of Xtool or other companies mentioned without written permission from the trademark holder.

## Responsibility

Use the device only as described in this manual. The user will be responsible solely for the after-effects of violating the laws and regulations caused by using the product or its data information, Xtool will not bear any legal responsibility for that. Xtool shall not be liable for any incidental or consequential damages or for any economic consequential damages arising from the accidents of individual users and the third parties, misuse or abuse of the device, unauthorized change or repair of the device, or the failure made by the user not to use the product according to the manual. All information, specifications and illustrations in this manual are based on the latest configurations and functions available at the time of printing. Xtool reserves the right to make changes at any time without notice.

## Safe

- This product is intended for use by automotive technicians only.
- When the engine is running, please keep the maintenance area well ventilated, properly connect the engine and the building's exhaust system. The carbon monoxide generated by the engine will cause the body to be unresponsive and even cause serious personal injury or death.
- Wear ANSI-compliant goggles and keep clothing, hair, hands, tools, diagnostics, etc. away from running or hot engine parts.

# 1. Overview

## 1.1. Introduction

H6 Pro is Xtool latest car diagnosis platform made for technicians. It consists of an tablet, which has 10.1-inch touch screen, 4GB RAM and 64GB on-board memory, a wireless VCI box, and other related connection parts. It Supports 20 kinds of special functions, covers more than 80+ car make, and 14 kinds of language. In addition, There are three ways to update app and system, including OTA, USB, and offline update. By using Xtool H6Pro, it will make your diagnosis work much easier, quicker, and more convenient.

## 1.2. Main host

### 1.2.1. Appearance



(Front view)

(Back view)

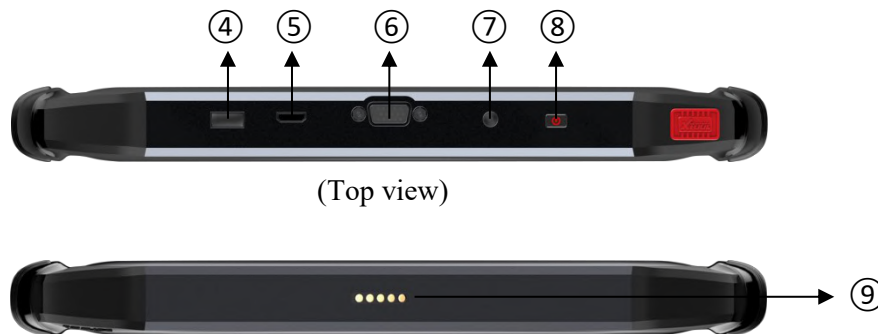

(Top view)

(Bottom view)

①: Camera	Take photo or video
②: Speaker	Sound comes out
③: Nameplate	Tablet model and SN information
④: USB3.0 interface	Data transfer via USB cable
⑤: Mini HDMI interface	Audio and video transfer
⑥: DB15 interface	Extended reservation port
⑦: DC port	Device charging, using 12V power
⑧: Power button	Power On/off button
⑨: Charger interface	A reserved charger interface

### 1.2.2. Parameter

Item	Description
Operating system	Android
Processor	Quad core processor 1.8GHz
Memory	4GB RAM, 64GB ROM
Screen	10.1 inch LED, 1280×800 resolution
Camera	Rear camera, 8.0 Megapixel, AF with Flashlight.
Ports	USB3.0, DC charging port, Mini HDMI, DB15 interface
Battery	13000mAh Lithium-polymer battery
Input voltage	12V voltage system
Working temperature	10 to 50°C (50to 122°F)
Relative humidity	<90%
Appearance size	310.92×189.17×36.21 (mm)

### 1.2.3. Power

The H6 Pro tablet can be powered by following methods:

➤ Built-in rechargeable battery

H6 Pro tablet has an built-in rechargeable battery, which can power the tablet without connecting to external power source. For the fully charged battery, it can power the tablet about 4 hour in continuous operation.

➤ AC / DC power

H6 Pro tablet can be powered by external power source through DC port with

recommend AC/DC adapter. In addition, the DC port and adapter are also be used to charge the built-in battery.

➤ Vehicle power

H6 Pro tablet can be powered by external power source through DC port from Cigarette lighter or other power supply device in vehicle. Please make sure the external power source can supply appropriate working power for tablet.

*Caution: Since the tablet contains lithium battery, it is forbidden to use this product in high temperature and high heat environments.*

### 1.3. VCI box

#### 1.3.1. Appearance



(Front view)

(Top view and bottom view)

- ①: Display                      Display voltage, Bluetooth connection status, etc.
- ②: DB15 port                  Work together with the extension cable and various types of connectors to communicate with vehicle diagnostic port
- ③: DB9 port                    Work together with DB9 male to USB3.0 cable to communicate with tablet

### 1.3.2. Parameter

Item	Description
Screen	1.54 inches
Power consumption	2 W
Connection	Wired/Bluetooth
Port	USB DB15 test main line interface
CPU	ARM processor
Material	Aluminum metal and reinforced plastic housing
RAM	1MByte

## 1.4. Accessories

### 1.4.1. Main cable

The main cable is used to connect VCI box and vehicle. After successfully building the communication between VCI box and tablet, the vehicle diagnosis data can be transmitted to tablet. In addition, the VCI box is also powered by vehicle with using main cable.



### 1.4.2. Vehicle adapters

The adapters are to connected different kind of vehicles. User should choose proper adapter depend on vehicle OBD port.

Note: some adapters are optional, please contact with Xool, or local distributor for more details





### 1.4.3. Other accessories

Note: some accessories are optional, please contact with Xool, or local distributor for more details



## 2. Activation

### 2.1. Activate process and operation

The H6 Pro tablet needs to be activated online for full function before usage. User only needs to operate the tablet according to the activation guidance on it.

Note: During the entire activation process, it needs to ensure a good network connection.

Activation steps:

1. Press the power button to turn on H6 Pro Tablet;
2. Swipe up and down to select language, and click [ NEXT ];

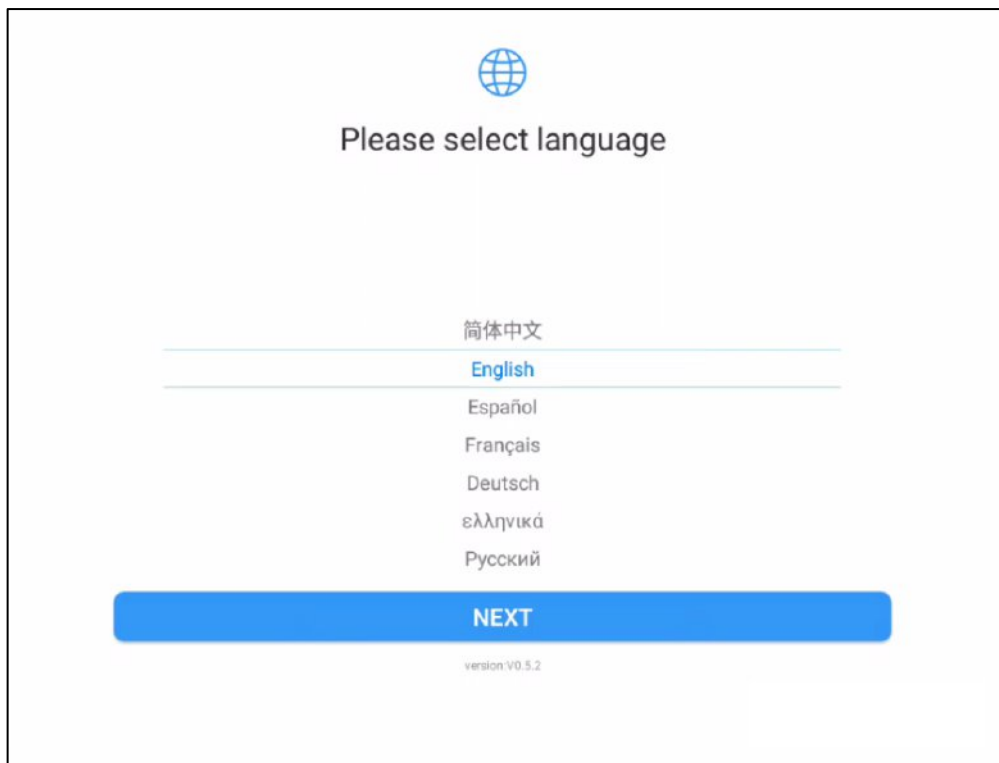

(Choose language)

3. Select WIFI to connect the tablet with internet. Click [ OK ];

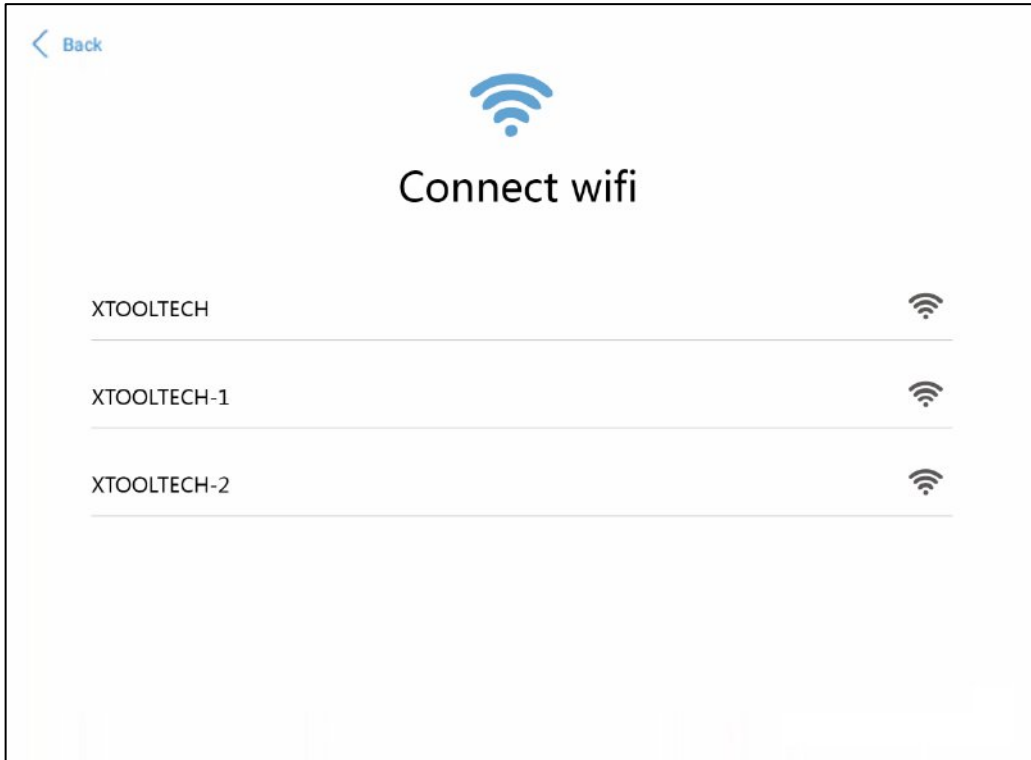

(Connect WIFI)

4. Tablet will enter activation wizard interface. Click [ START ACTIVATE ].

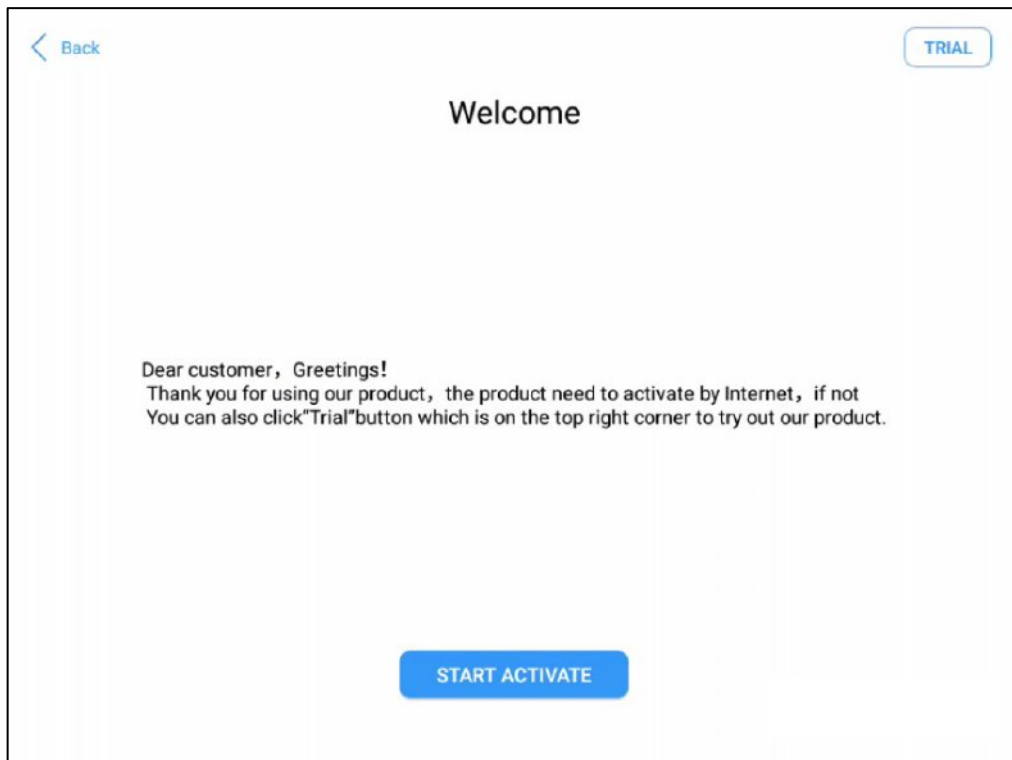

(Start activate)

5. Enter user personal or company e-mail. Click [ OK ], then tablet will activate automatically. There will be a notification if activation is successful.

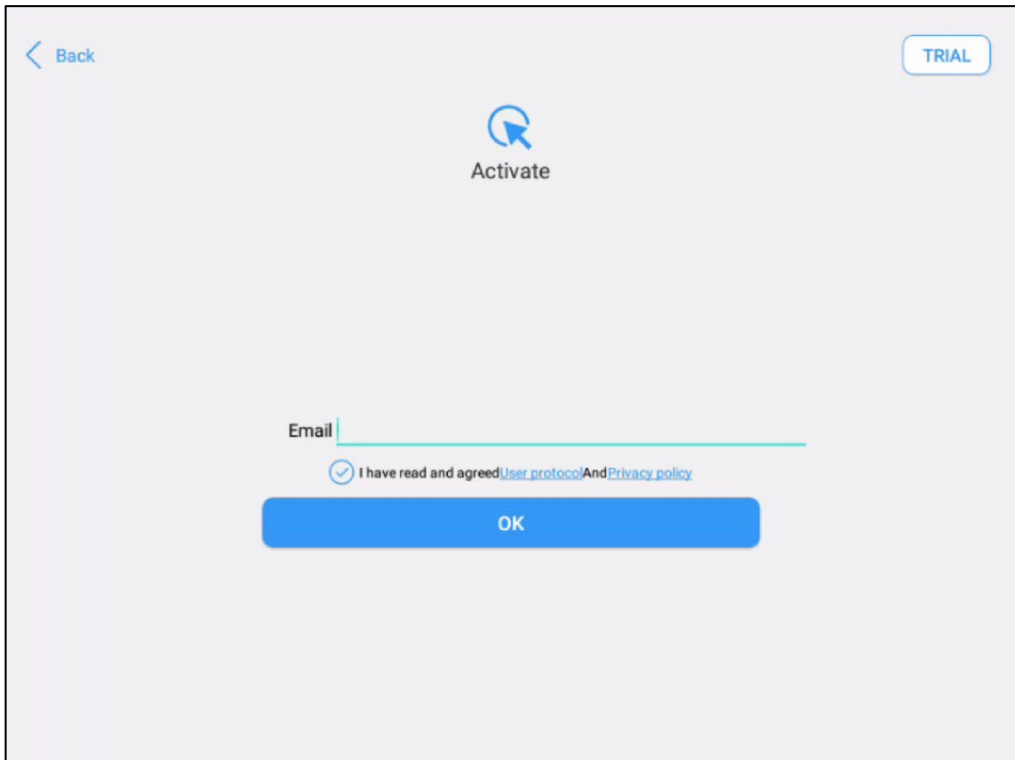

(Enter email address)

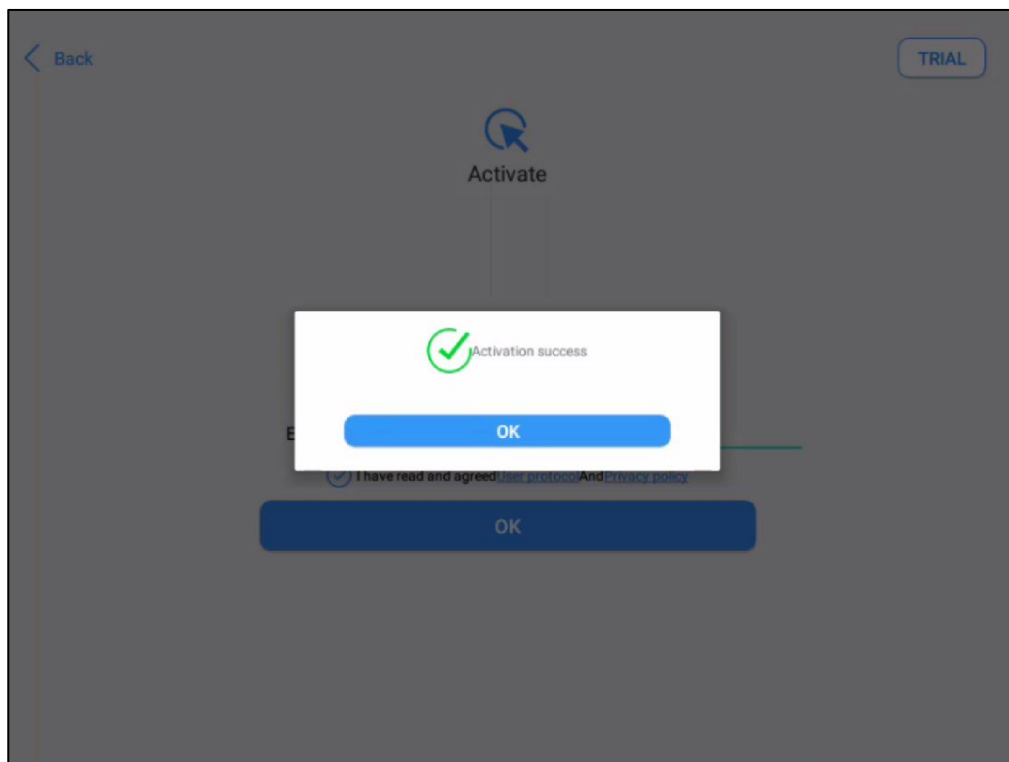

(Activation success)

Note: If activation fails, please contact the Xtool or distributor.

## 2.2. Update first time

For the first time use, customer needs to update the content to get some basic function. Open Xool Diagnosis App, and click [ Update ].

User can select the update content depends on actually needs, or can also update all the software in once.

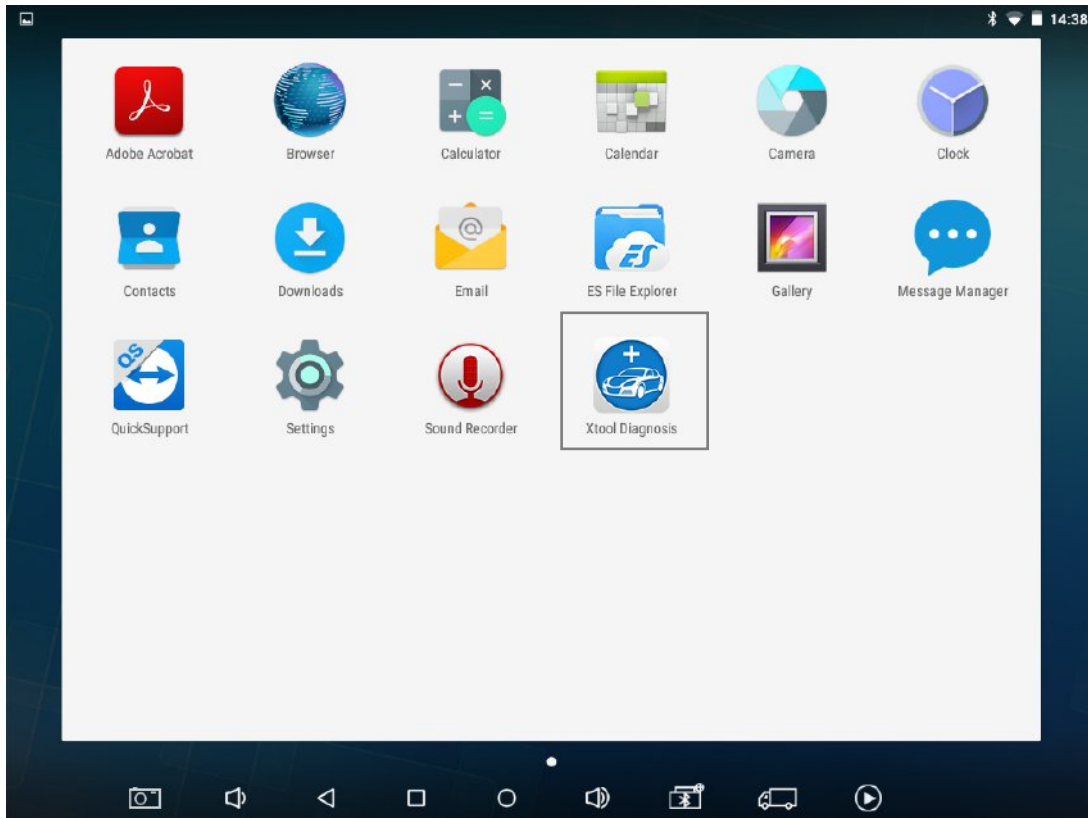

(Xtool Diagnosis APP)



[ Update ]

	Module Name	Version	Last Update	Progress	Action
1	DIAGNOSIS-AUDI	V10.96	2020-10-23 09:52:13	0%	Update
2	DIAGNOSIS-BENTLEY	V10.96	2020-10-23 09:52:16	0%	Update
3	DIAGNOSIS-BUGATTI	V10.96	2020-10-23 09:52:19	0%	Update
4	DIAGNOSIS-CVWW	V10.96	2020-10-23 09:52:21	0%	Update
5	DIAGNOSIS-LAMBORGHINI	V10.96	2020-10-23 09:52:24	0%	Update
6	DIAGNOSIS-SEAT	V10.96	2020-10-23 09:52:27	0%	Update
7	DIAGNOSIS-SHW	V10.96	2020-10-23 09:52:31	0%	Update
8	DIAGNOSIS-SKODA	V10.96	2020-10-23 09:52:33	0%	Update
9	DIAGNOSIS-VW	V10.96	2020-10-23 09:36:43	0%	Update

[ Update ]

## 3. Vehicle Connection

### 3.1. Connection procedure

To get full and right diagnosis function, user needs to connect the H6 Pro tablet and vehicle properly.

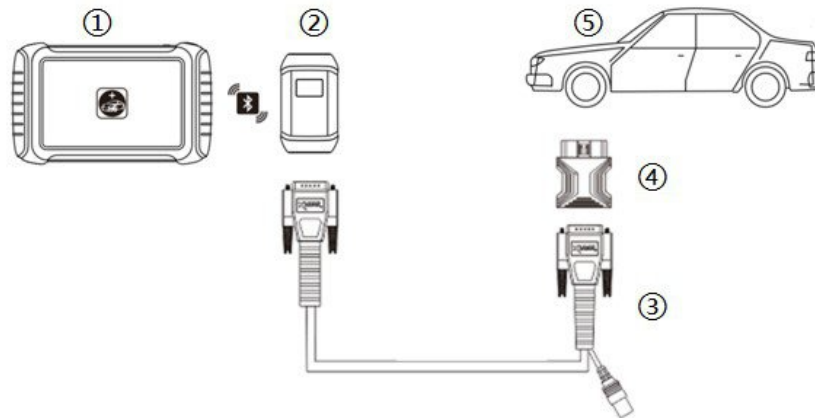

(Vehicle connection diagram)

- ①: H6 Pro Tablet
- ②: VCI box (communication with the tablet by wire or Bluetooth connection, and connect with
- ③④components to vehicle OBD port)
- ③: Main cable
- ④: OBDII-16 Adapter (Select other adapters when the diagnostic port is a non-standard OBDII 16pin connector)
- ⑤: Diagnosed vehicle

Connection step:

1. Turn on the car ignition switch, and H6 Pro Tablet
2. Choose proper OBD II adapter, and connect it with the main cable and vehicle
3. Connect the VCI diagnostic box to the main cable, and wait for 5 seconds for Bluetooth to connect the tablet successfully
4. Open diagnosis app, and select the function for vehicle fault diagnosis

## 4. Function and diagnosis operation

### 4.1. Interface

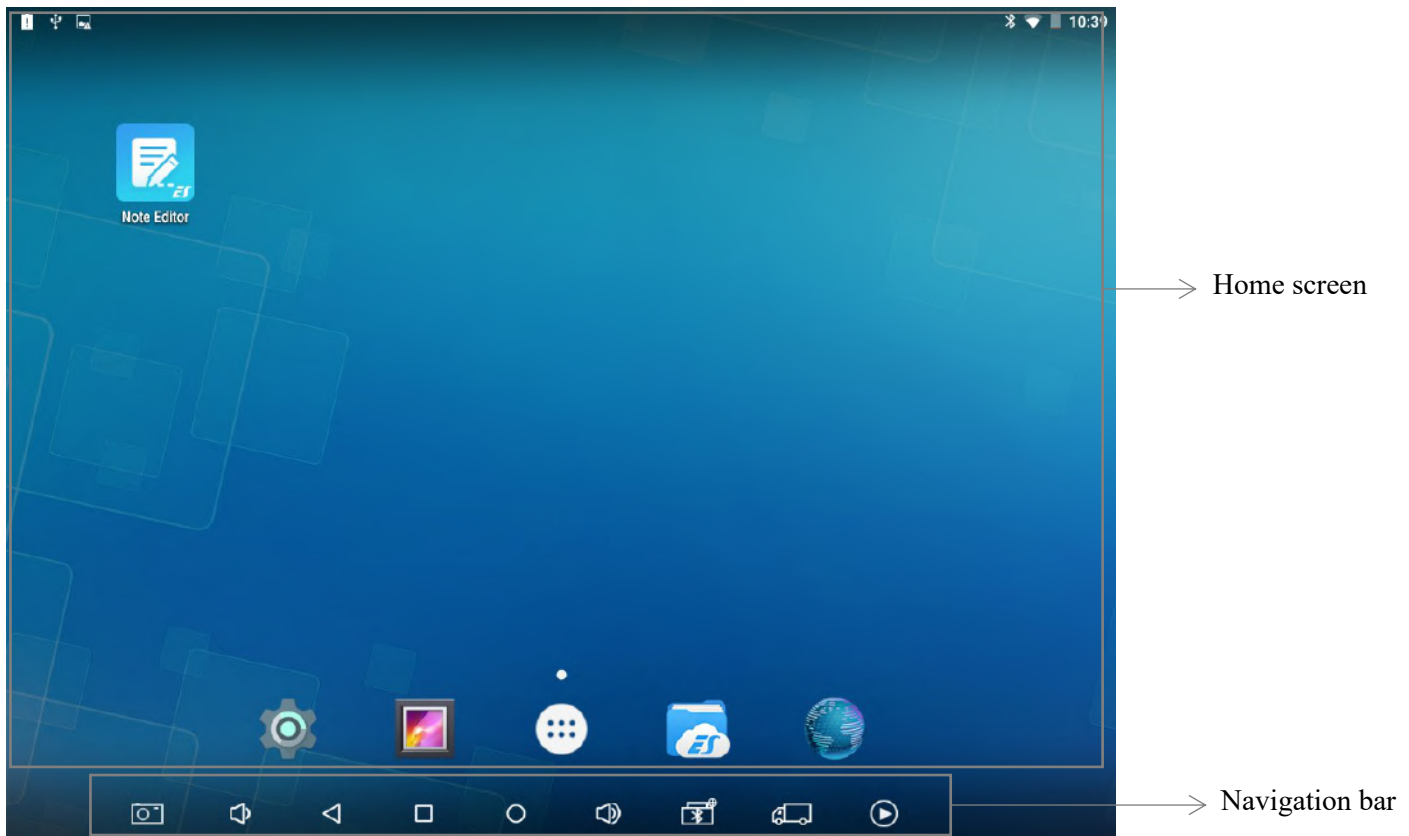

#### 4.1.1. Tablet OS Interface

The H6 Pro tablet OS is based on Android OS, so most of the operations are as same as those on other consumer tablets with Android OS. But to meet with the actual diagnosis demand, Xtool has also added some special operations on it.









(Tablet OS main interface)

Description of navigation bar:

Button	Description
 <b>【Screenshot】</b>	Take a quick screenshot
 <b>【Volume decrease】</b>	Decrease speaker volume



 <b>【Return】</b>	Return to the previous interface
 <b>【Recently】</b>	Show recently used APP
 <b>【Home screen】</b>	Return to the home screen of Android
 <b>【Volume increase】</b>	Increase speaker volume
 <b>【Bluetooth connection】</b>	Indicate Bluetooth connection, show blue if properly connected
 <b>【Diagnosis】</b>	Directly back to the diagnosis mode interface
 <b>【Screen record】</b>	Record the operations displayed on screen





#### 4.1.2. Xtool Diagnosis APP Interface



Xtool diagnosis APP is the core application of H6 Pro tablet, which allows user to perform diagnosis function, output report, and other related operations.



(Xtool diagnosis app main interface)

Description of function button:

Button	Description
 <p><b>【Account】</b></p>	User account information, including name, and SN
 <p><b>【Diagnosis】</b></p>	Core function used to vehicle diagnosis
 <p><b>【Settings】</b></p>	Set language, unit, bluetooth
 <p><b>【Xcloud】</b></p>	Linked to Xtool official website to provide tutorial video or other technical information
 <p><b>【Update】</b></p>	One click update to get latest diagnosis software

 <b>【Report】</b>	Check vehicle diagnosis report and video
 <b>【Remote】</b>	Solve problem by remote control through internet

## 4.2. Setting

This function is used for user to set language, unit, and user information according to user preference before diagnosis

Language: it will show different depend on version

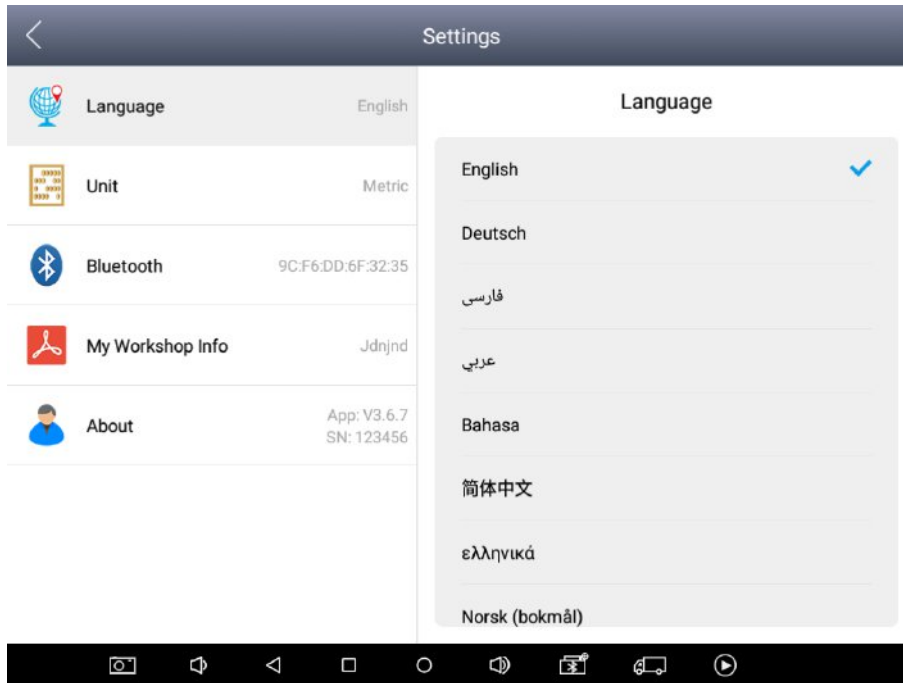

( [ Settings ] --> [ Language ] )

Unit: user can select Merit or British unit

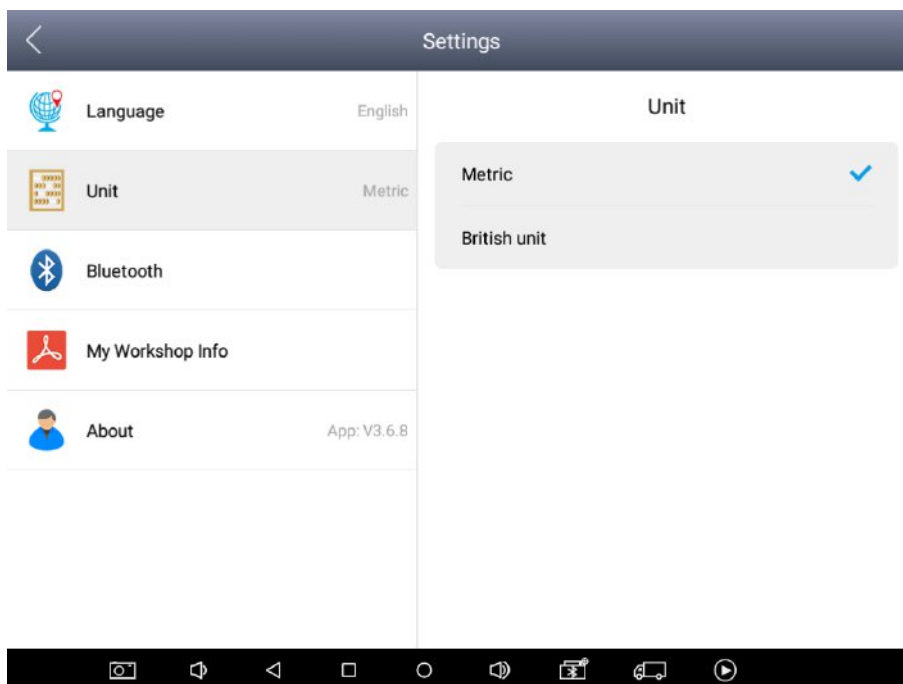

( [ Settings ] --> [ Unit ] )

Bluetooth: it will show the VCI box connection, and information

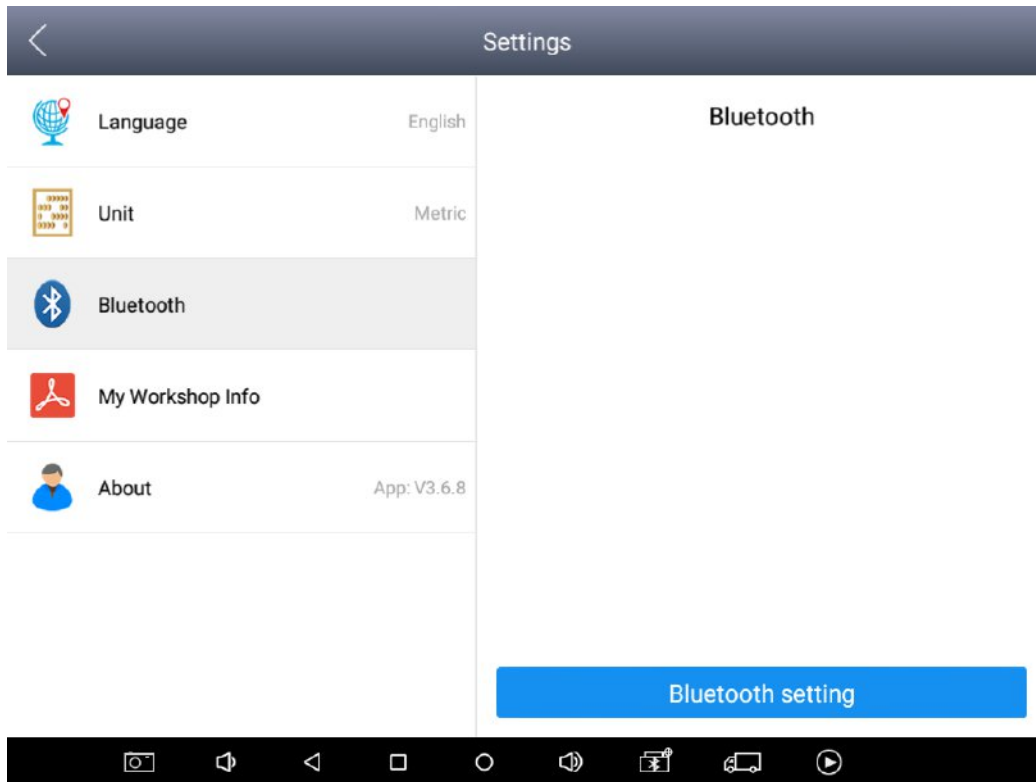

( [ Settings ] --> [ Bluetooth ] )

My Workshop Info: user can input information used for the diagnosis report

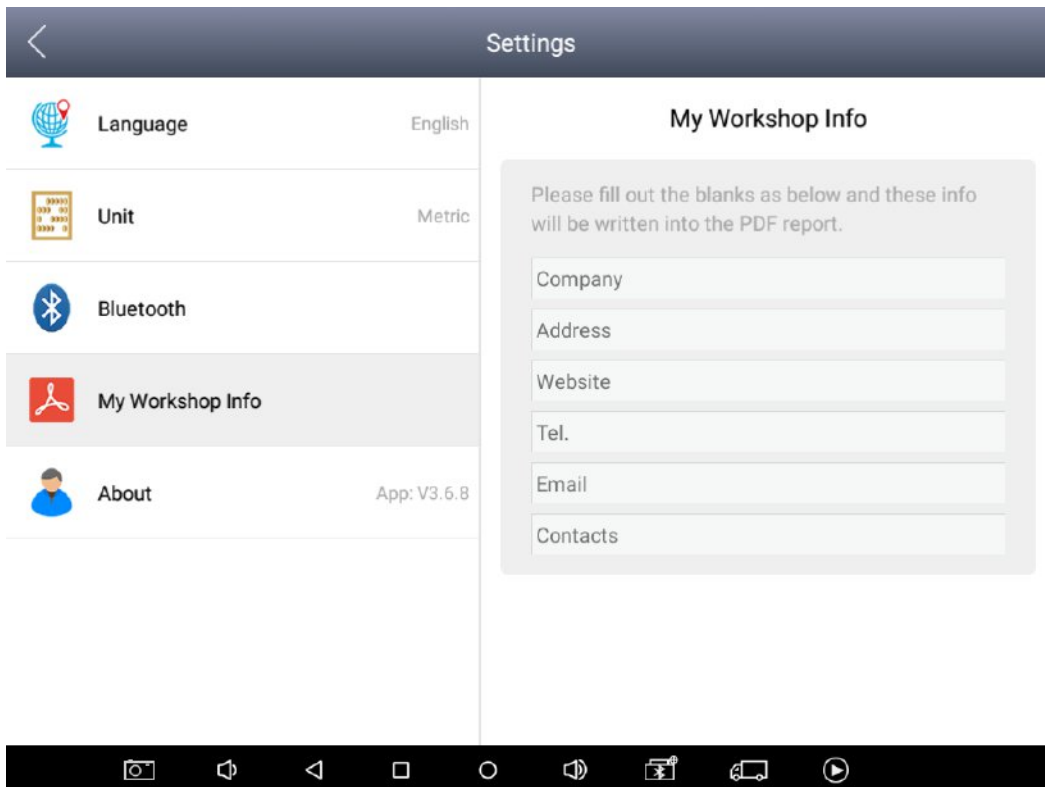

( [ Settings ] --> [ My Workshop Info ] )

## About: it shows the app version

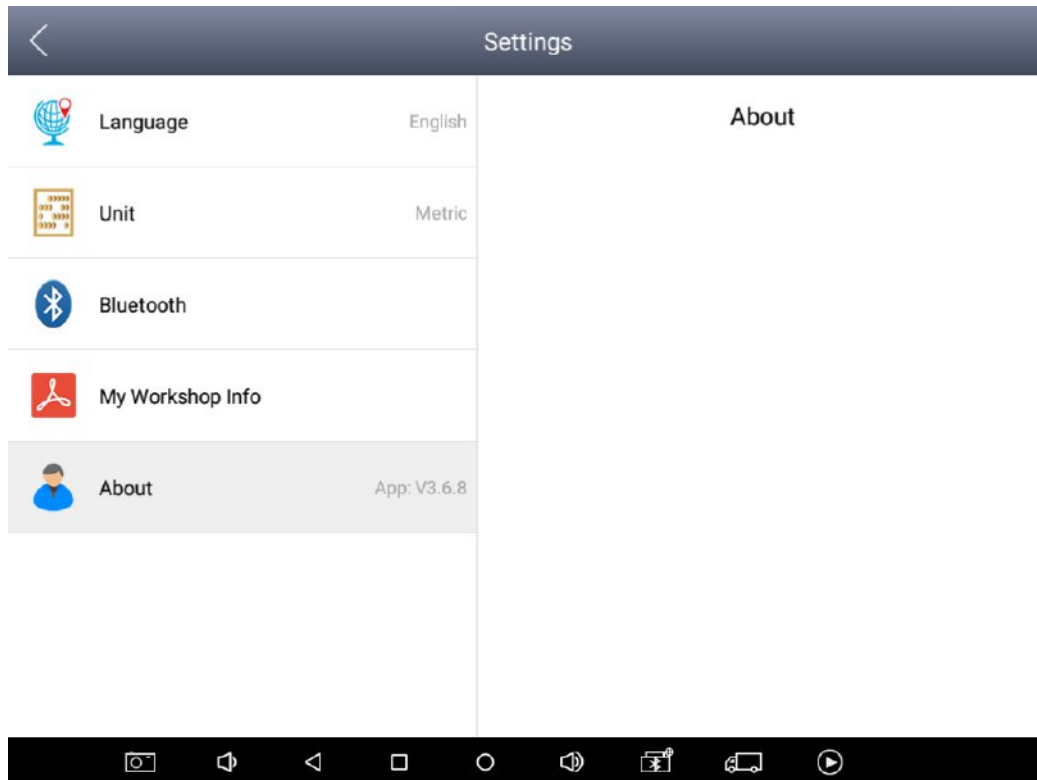

( [ Settings ] --> [ About ] )

### 4.3. Diagnosis

This function is the core function of H6 Pro diagnosis application. It is used to vehicle diagnosis and maintenance service.

Note: user should update the software to latest version before using the diagnosis function.

#### 4.3.1. VIN

The H6 Pro diagnosis application features the latest VIN identification function to check vehicles model in just one touch, which allows the technician to quickly detect vehicles, scan all the unit on it and run diagnosis test on the selected system.

It provides three ways to get the VIN of vehicle: including [ AUTO SCAN ], [ SCAN CODE ], [ MANUAL ENTER ]



(VIN selection)

AUTO SCAN: the tablet will get the VIN automatically when vehicle is connected with tablet.

SCAN CODE: use camera on tablet to scan the vehicle VIN.

MANUAL ENTER: input the 17-digit VIN code manually.

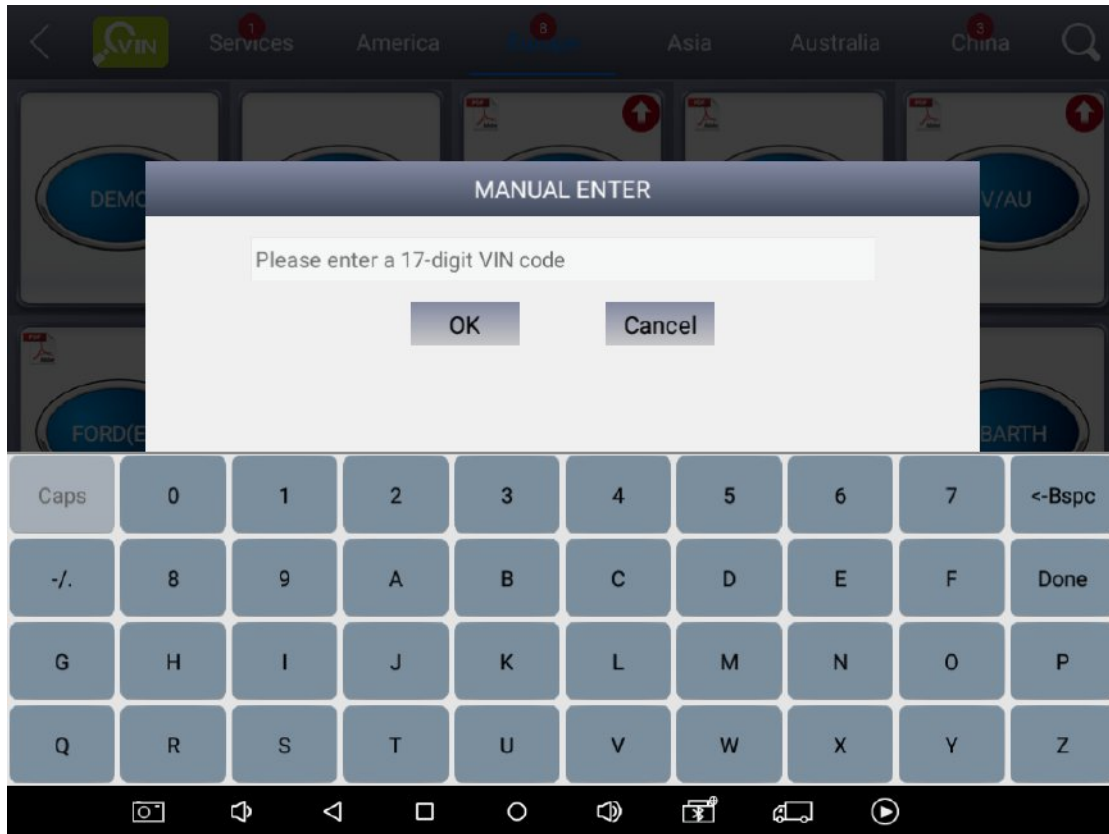

( [ VIN ] --> [ MANUAL ENTER ] )

### 4.3.2. Vehicle selection

The H6 Pro diagnosis application offers the menu for user to select the right vehicle model information according to the order: [ Brand ] --> [ Manual selection ] --> [ Model ] --> [ Year ] --> [ Version ]. The selection order will have some differences among different vehicle brands.

**Brand:** The H6 Pro diagnosis application provides two methods to find the vehicle brand for further identify its model.

- By search: user can directly input the vehicle brand name to search it.  
*(Take “volvo” as an example for following description)*





( Quick search  on top right corner )

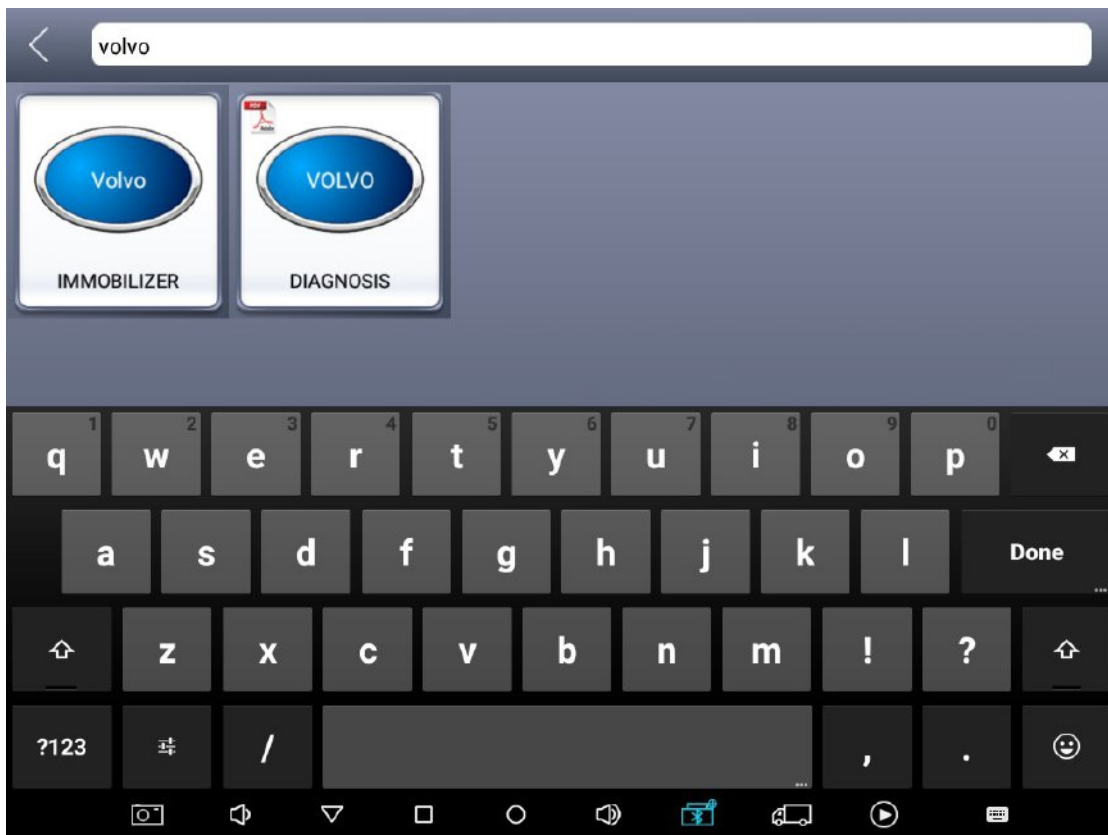

( Input vehicle brand “volvo”, and click [ VOLVO DIAGNOSIS ] )

➤ By menu selection: user can select vehicle manufacture region (Europe/America/Australia/China), and then swipe the screen up and down to find the brand



( [ Europe ] --> [ VOLVO ] )

**Automatic scan / Manually select:** After confirming the vehicle brand, user can choose to directly run the scanning diagnosis by clicking, which the vehicle model will be identified automatically, or manual to further confirm the vehicle model.

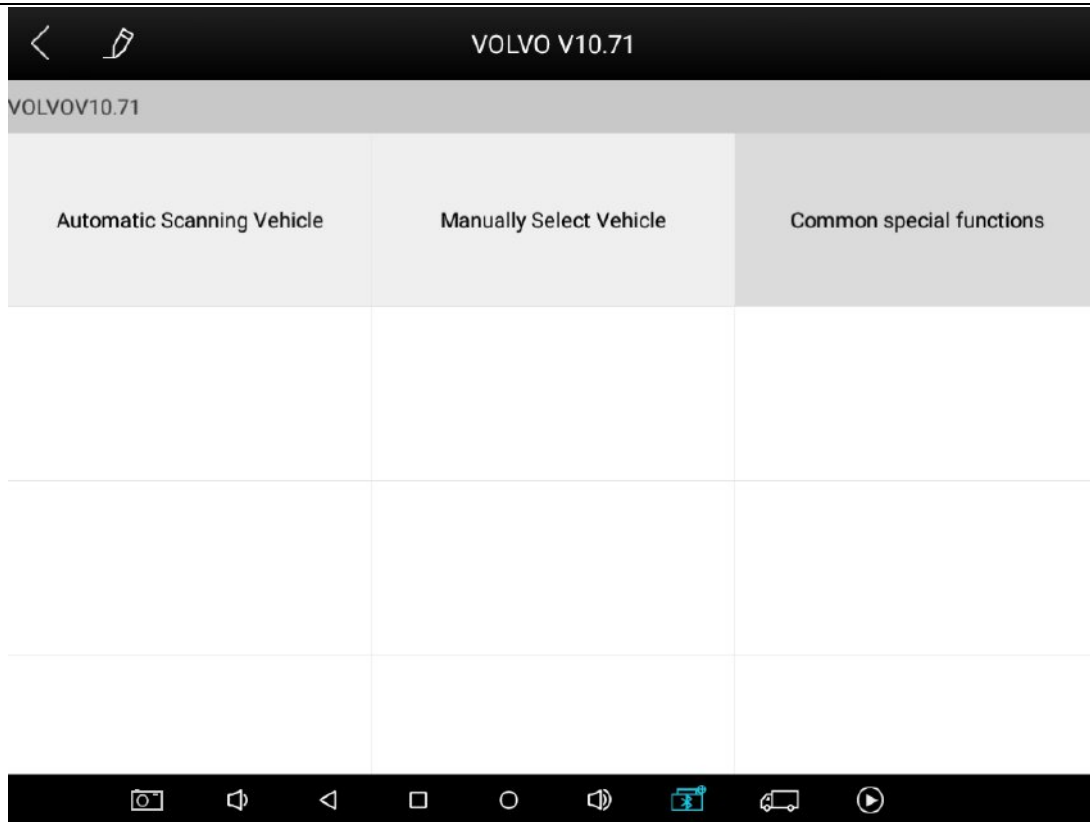

( [ Automatic Scanning ] / [ Manually select ] )

**Model:** Vehicle classification of models defined by manufacture

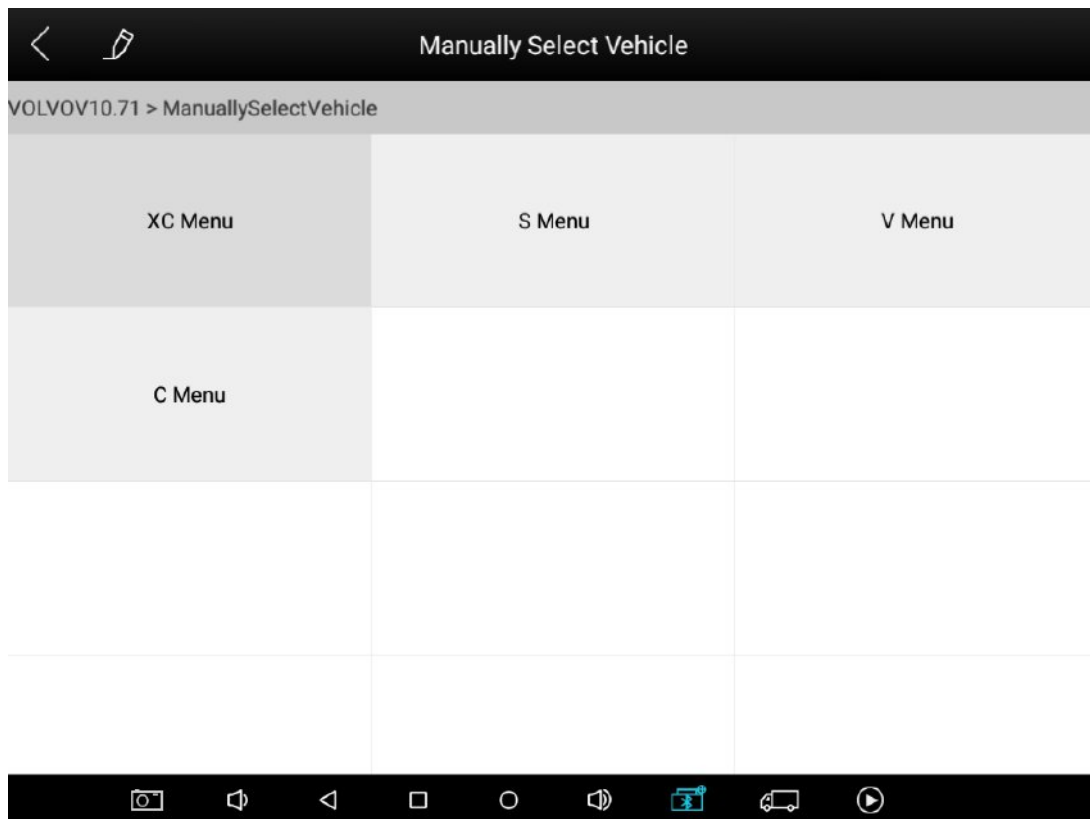

( Manually select vehicle menu )



( Model menu )

**Year:** The year of vehicle that defined by manufacture



( Year menu )

**Version:** The version information, according to engine, function or other information, used to classify vehicle model defined by manufacture

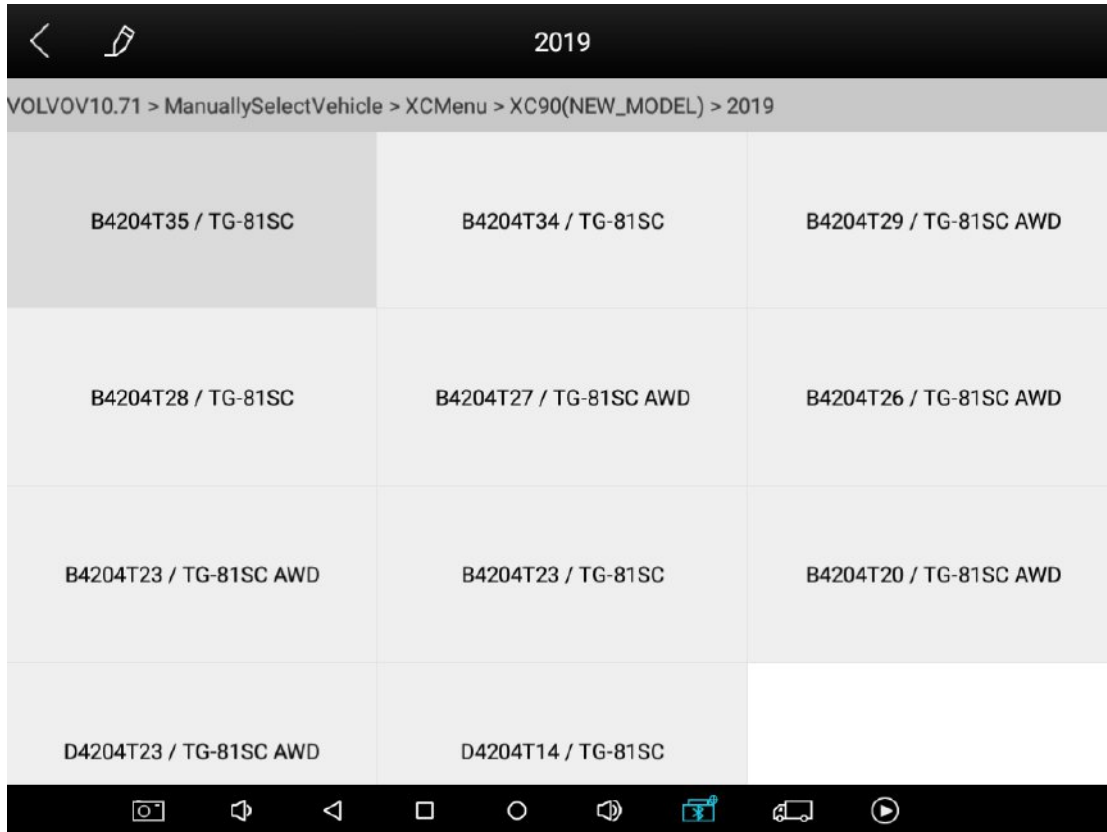

( Version menu )

### Demo

This function is mainly used as an demonstration for user to learn the basic operations. User can view most of the diagnosis functions in Xtool H6 Pro without actually changing any settings.

### OBD II

This function allows user to do a quick check for OBD II/EOBD vehicle diagnosis. User can use it to check for DTCs, isolate the cause of an illuminated malfunction indicator lamp (MIL), check monitor status prior to emissions certification testing, verify repairs, and perform a number of other services that are emissions-related. H6 Pro supports various vehicle OBD-II protocols, including SAE J1850 PWM, ISO 14230-4, etc.

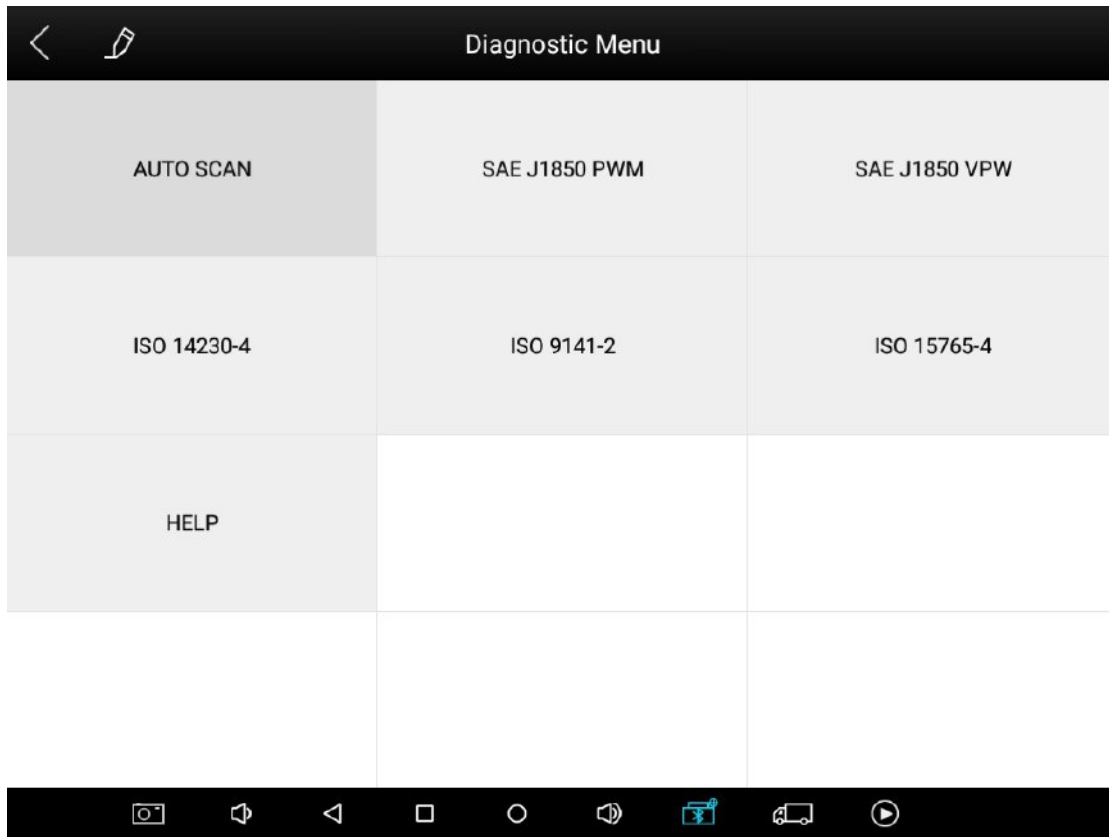

( [ OBD II ] )

### 4.3.3. Function

There will be some differences among different vehicle models. Xtool H6 Pro will enter diagnosis function after confirming vehicle model and control unit to be diagnosed. User can choose to scan the whole vehicle system by selecting [ Auto scan ], or just some units by selecting [ Control unit ].

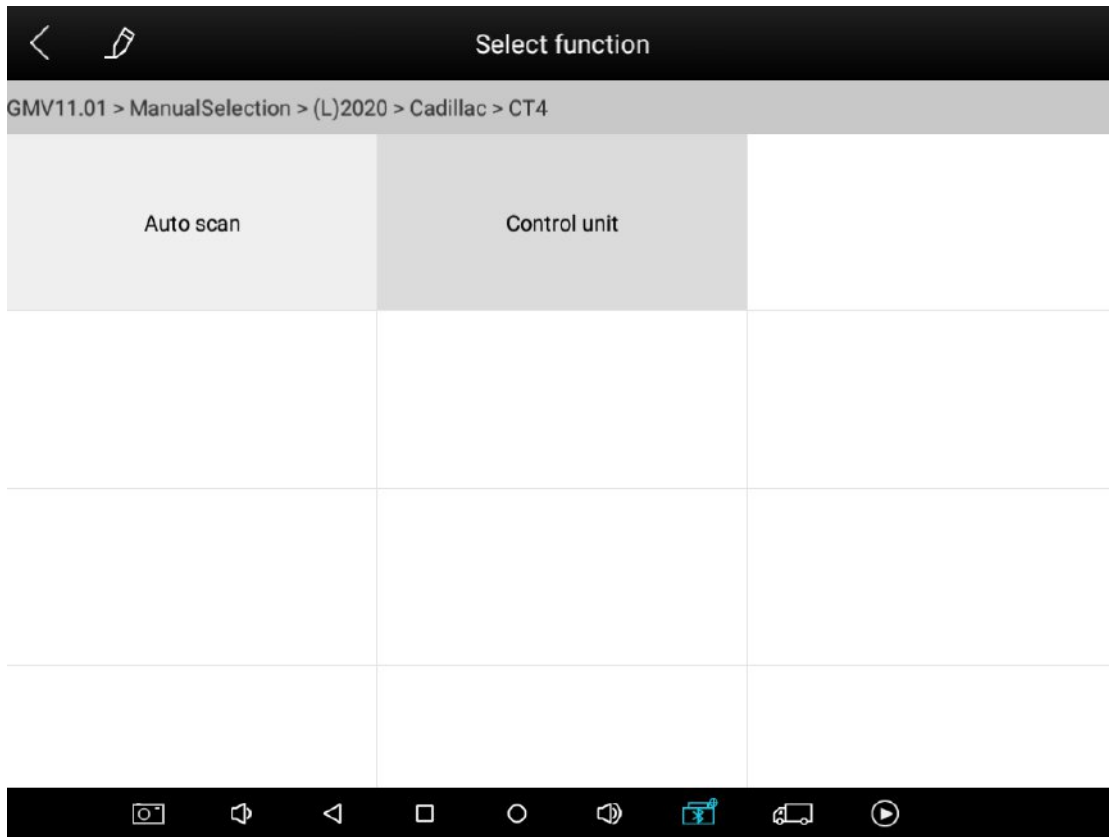

( [ Auto scan ] / [ Control unit ] )



( Control unit selected for diagnosis )

The normal diagnosis function includes reading ECU version information, Read ECU information, Read Trouble Code, Clear Trouble Code, Live data, Actuation test, and some special functions

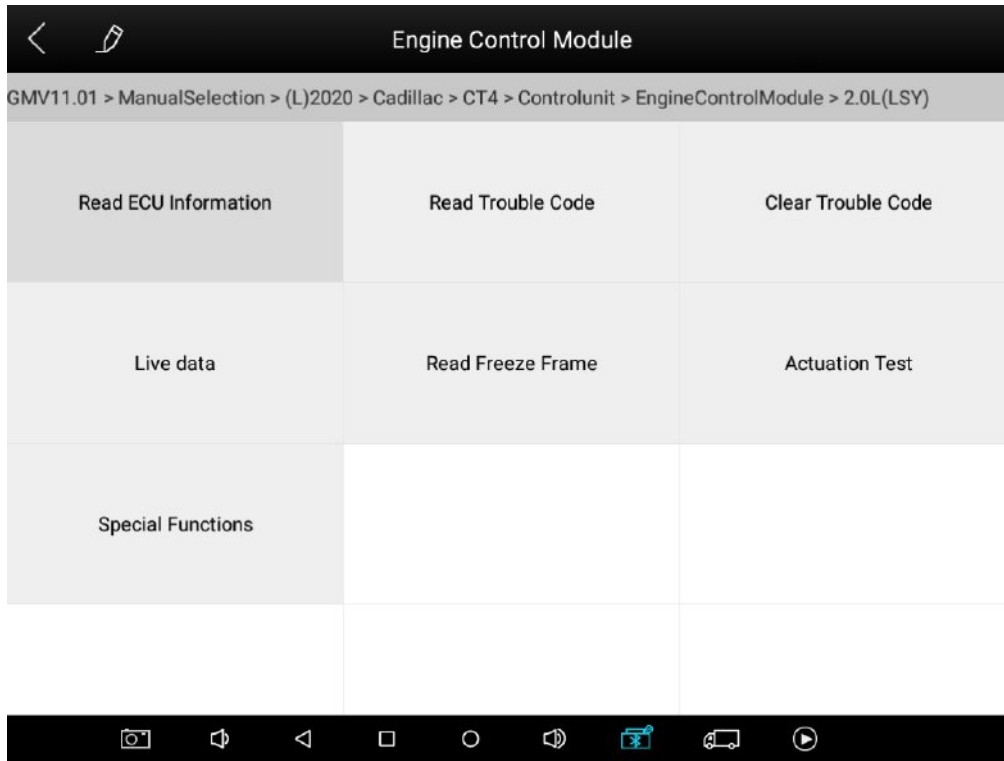

( diagnosis function )

### 1) Read ECU Information

This function allows user to read ECU version information. Some electronic control system display system identification or system information menus, which have the same meaning, and read information such as software, hardware version numbers, part numbers, and etc. .



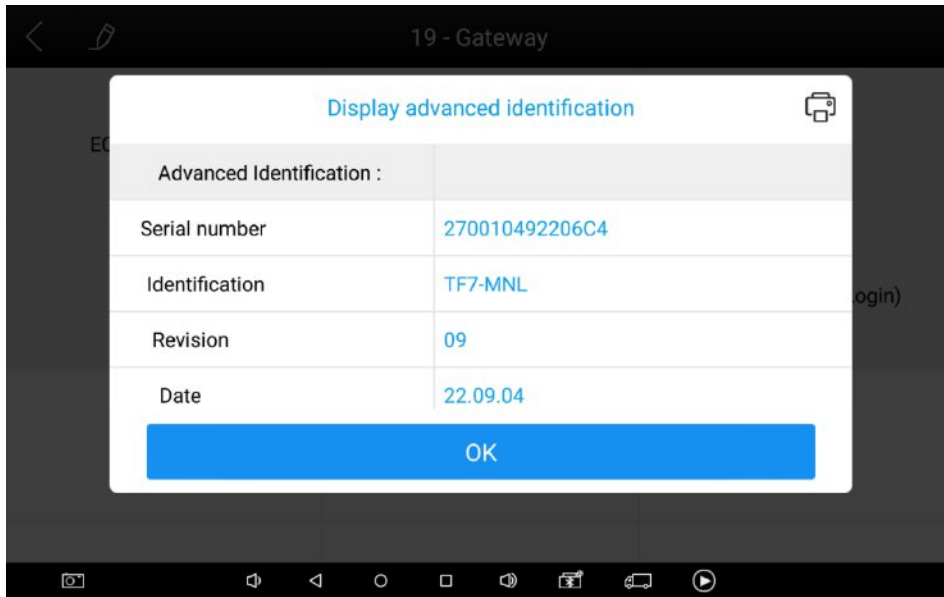

(Read ECU information )

### 2) Read Trouble Code

This function allows user to read the fault code stored in the electronic control ECU. When the fault code is read, the screen will display it and its definition.

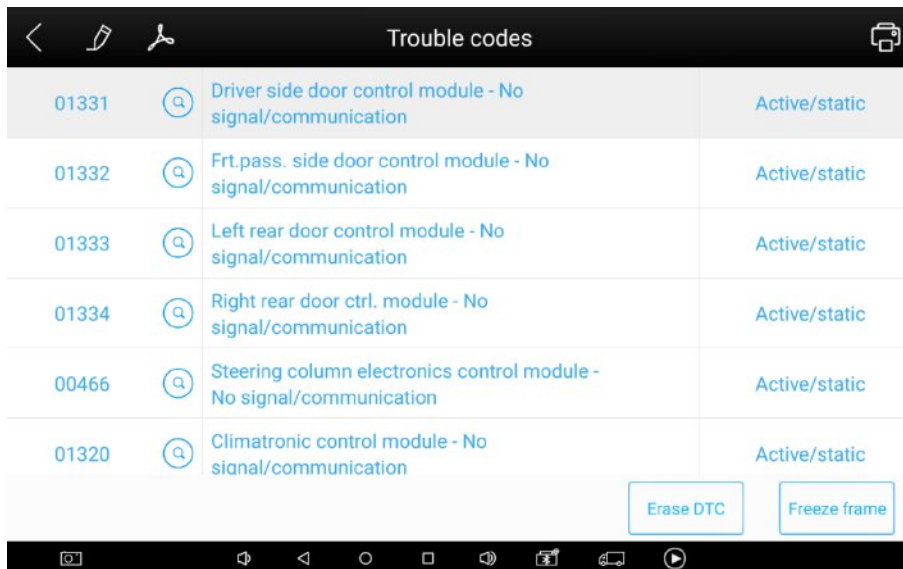

(Read Trouble code )

### 3) Clear Trouble Code

This function allows user to clear current and historical trouble codes memory in ECU. The trouble codes cannot be erased without eliminating the related fault. If a problem

is not solved, the related code will remain, and be stored in ECU, which leads to it can be read by diagnostic.

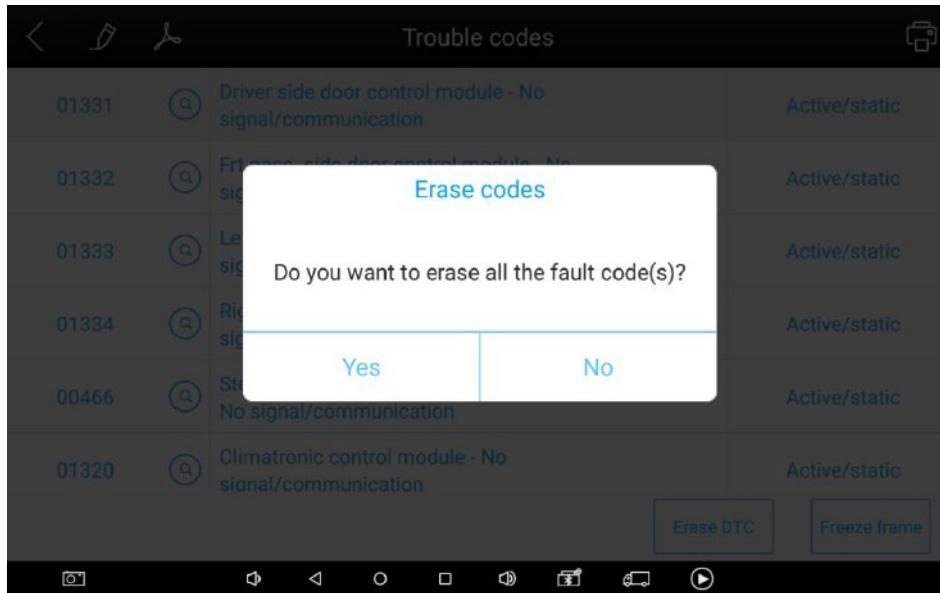

(Clear Trouble code )

Note:

- Save or print the currently stored fault codes before clearing them in the case of an intermittent fault, or for further main maintenance. If a problem is solved, the related code will disappear.
- Recommend to read the ECU code again to reconfirm that previous fault codes has been cleaned

#### 4) Read Live Data

This function allows user to read the parameters of the system on operating condition, such as oil pressure, temperature, engine speed, fuel oil temperature, coolant temperature, intake air temperature, etc. By analyzing these parameters, user can find out which part works abnormally, and narrow maintenance scope.

Live Data is important function that can be used to help experienced user to further diagnosis a problem. This function requires users to be familiarized with sensor data of each system, control signals and control modes.

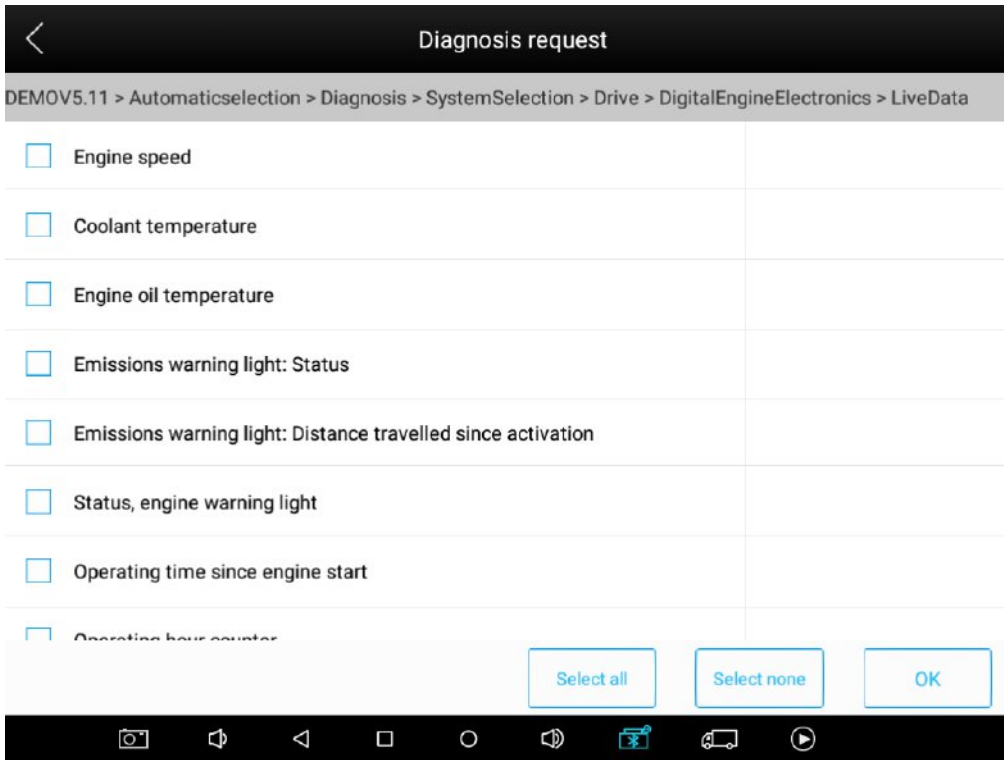

(Select unit to read live data )

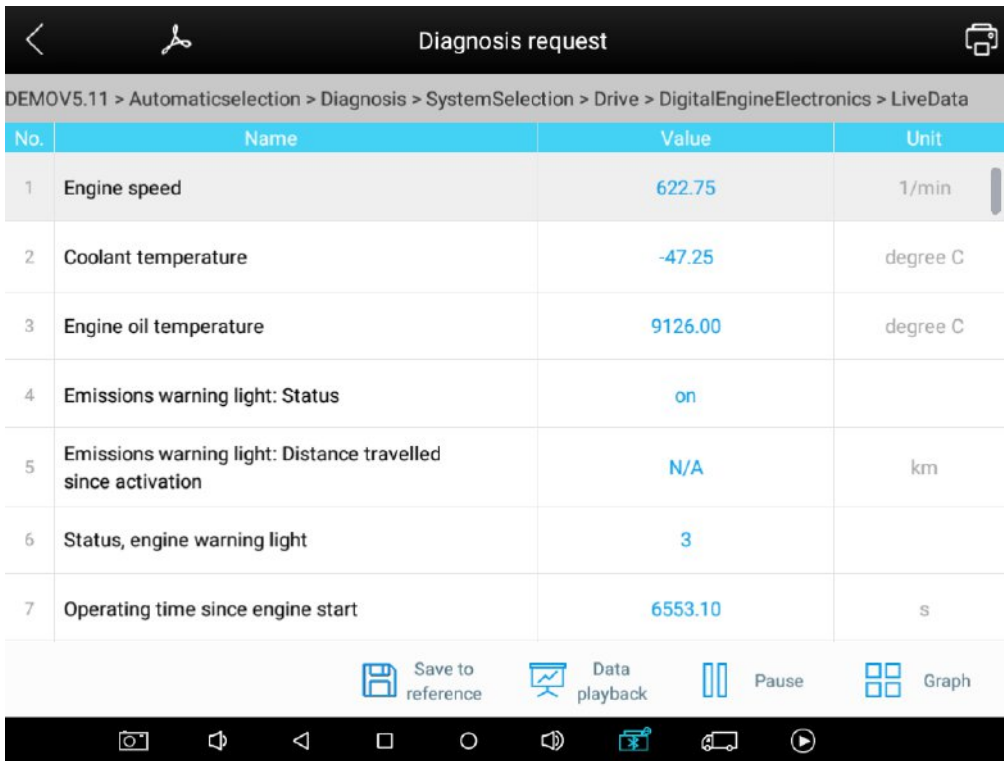

(Read live data)



(Graph mode)

5) Read Freeze Frame

This function allows user to read the trouble codes that are stored in the ECU at the moment, when vehicle has faults.

6) Actuation test

This function allows user to figure out whether a specific subsystem or component in the car works well or not, and to make the tester outputs function.

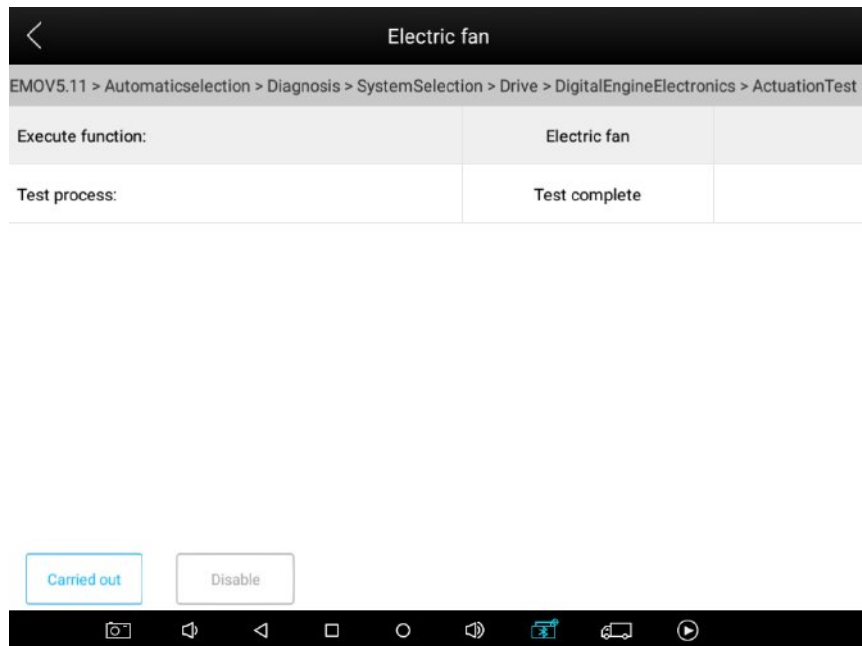

(Carried out or disable actuation test)

### 4.3.4. Service

This function is specially designed to provide user a quick access to the vehicle for various service and maintenance. By selecting service and related vehicle model, user can complete the service performance according to instructions on screen. The most common used service functions are as follows.

#### 1. Service / Maintenance Light

This function allows user to reset for service information of the engine system, which calculates and predict the oil life change interval depend on the vehicle driving conditions. The engine system oil reminder must be reset every time if oil is changed, so the system can calculate the next time to change oil.

#### 2. Electric Parking Brake

This function has a multitude of usages to maintain the electronic braking system safely and effectively. The applications include deactivating and activating the brake control system, assisting with brake fluid control, opening and closing brake pads, and setting brakes after disc or pad replacement, etc.

#### 3. Throttle Relearn

This function allows vehicle throttle body relearn to establish a new baseline idle. Many car makers install wire electronic throttle bodies. A motor and gear reduction set inside the throttle body opens and closes the throttle plate to accomplish your request. Over time, carbon buildup can accumulate around the throttle plate, changing it's "home" position. If the buildup occurs gradually, the PCM "learns" the new home position.

#### 4. Window Initialization

If user replaces a window motor or window regulator and the glass doesn't travel the full distance, user may needs to perform a learn or initialization procedure. Many vehicles require a window initialization procedure to "learn" when the window is in the full up and full down position.

## 5. Tyre Pressure Reset

This function allows user to quickly look up the tire sensor IDs from the vehicle's ECU, as well as to perform TPMS programming and reset procedures after tire sensors are replaced.

## 6. ABS Bleeding

This function allows user to perform a diagnosis to check the operating conditions of Anti-lock Braking System. Whenever user are replacing components in braking systems or brake fluid gets older, there is the tendency of air seeping in. The air in brake lines can make brakes malfunction, especially for cars equipped with anti-lock systems. Properly bleeding ABS brakes is essential, especially with this system becoming an essential part of nearly all vehicles for safety reasons.

## 7. Immobilization

The Immobilization service can disable a lost vehicle key. An immobilizer is an anti-theft mechanism that prevents an automobile's engine from starting unless the correct ignition key or other device is present. It is also considered as providing much more effective anti-theft protection than an audible alarm alone;

## 8. BMS Reset

The Battery Management System (BMS) allows user to evaluate the battery charge state, monitor the close-circuit current, register the battery replacement, activate the rest state of the vehicle, and charge the battery via the diagnostic accessory.

## 9. Steering Angle Sensor Adjustment

This service function allows you to perform calibration for the Steering Angle Sensor, which permanently stores the current steering wheel position as the straight-ahead position in the steering angle sensor EEPROM. On successful completion of the calibration, the steering angle sensor fault memory is automatically cleared.

## 10. DPF

The Diesel Particulate Filter service function performs the regeneration procedure which is the DPF cleaning operation to clear the blockage through continuous burning of the particulate matter captured in the DPF filter. If the DPF light on the vehicle comes on and you successfully complete a DPF regeneration cycle, you will notice that the DPF light will automatically turn off.

### 4.3.5. Operation record and diagnosis report

The H6 Pro tablet provides specified function to help user record the operation and generate diagnosis report for further analysis. User can use screen shot, screen recording, and Xtool special tool to record the operation and data.

**Operation record:** The operation record can be used to help customers solve problems about the product itself encountered in the use of it.

- Use the screen shot and screen recording function on navigation bar to record the operation on screen.

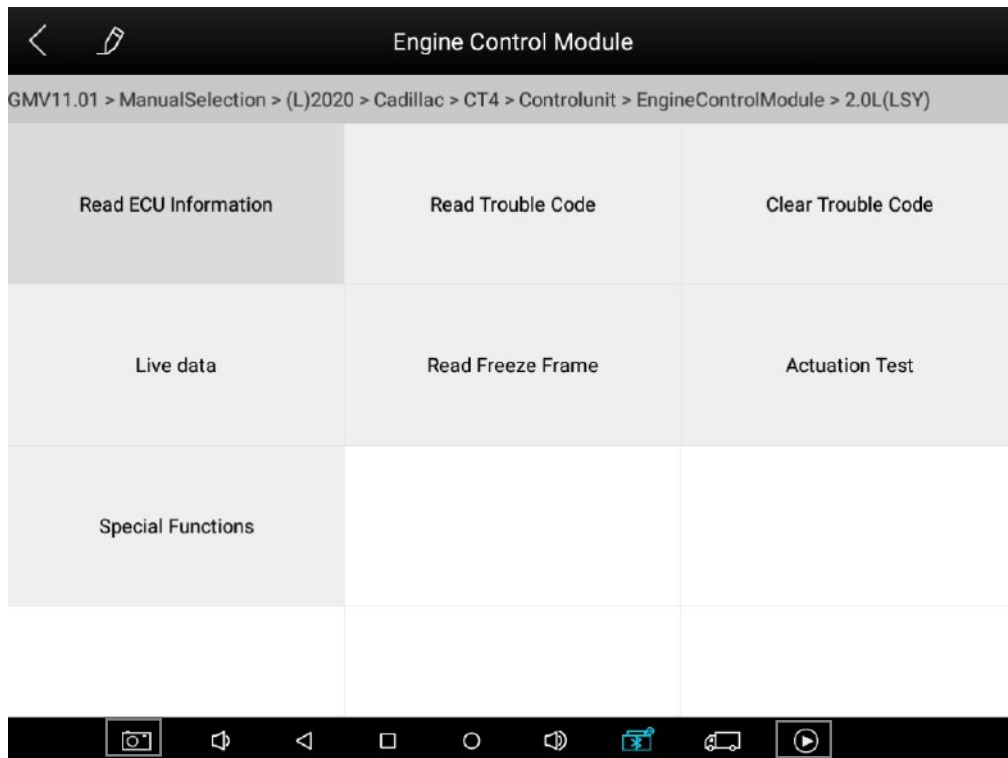

(Screen shot and recording button on navigation bar)

- Use Xtool special record tool  to record the operation. During diagnosis

progress, there will be a pencil like icon on the left up corner. User needs to click one time to start the record function, then the icon is flashing. If user needs to stop the record, click it again. Then it will jump into a send interface automatically. Click [ Send ], the record will be sent to Xtool official technical support email.



(Xtool special record tool )

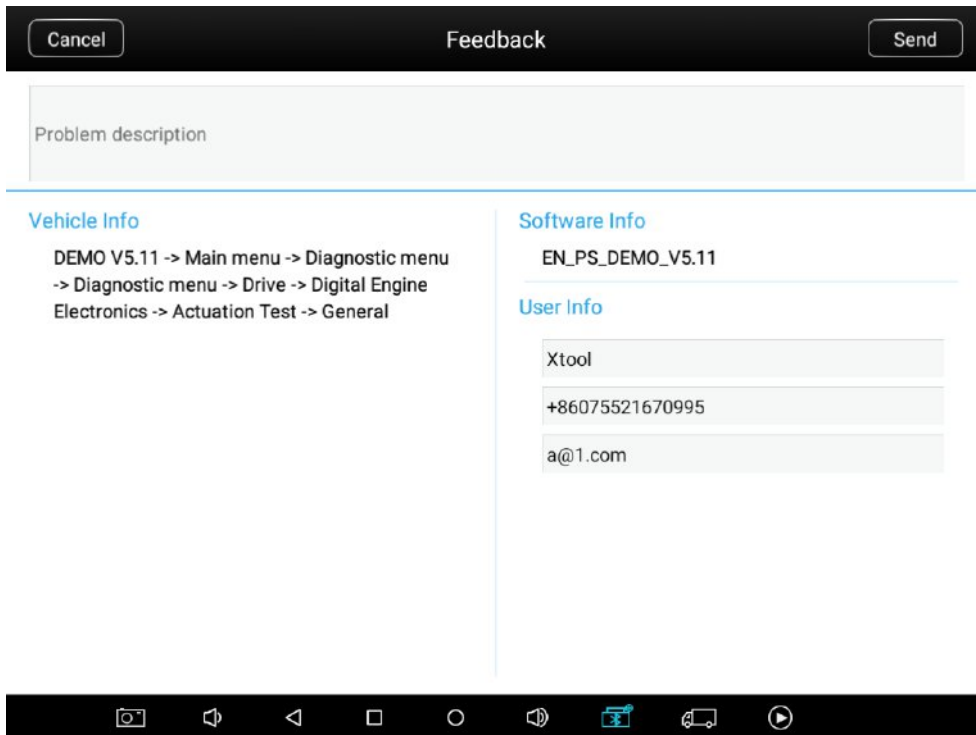

( [Send] )



**Diagnosis report:** This function is mainly used to generate a PDF diagnosis result of the vehicle after finishing the diagnosis. User can save, print, or send it to others for viewing.

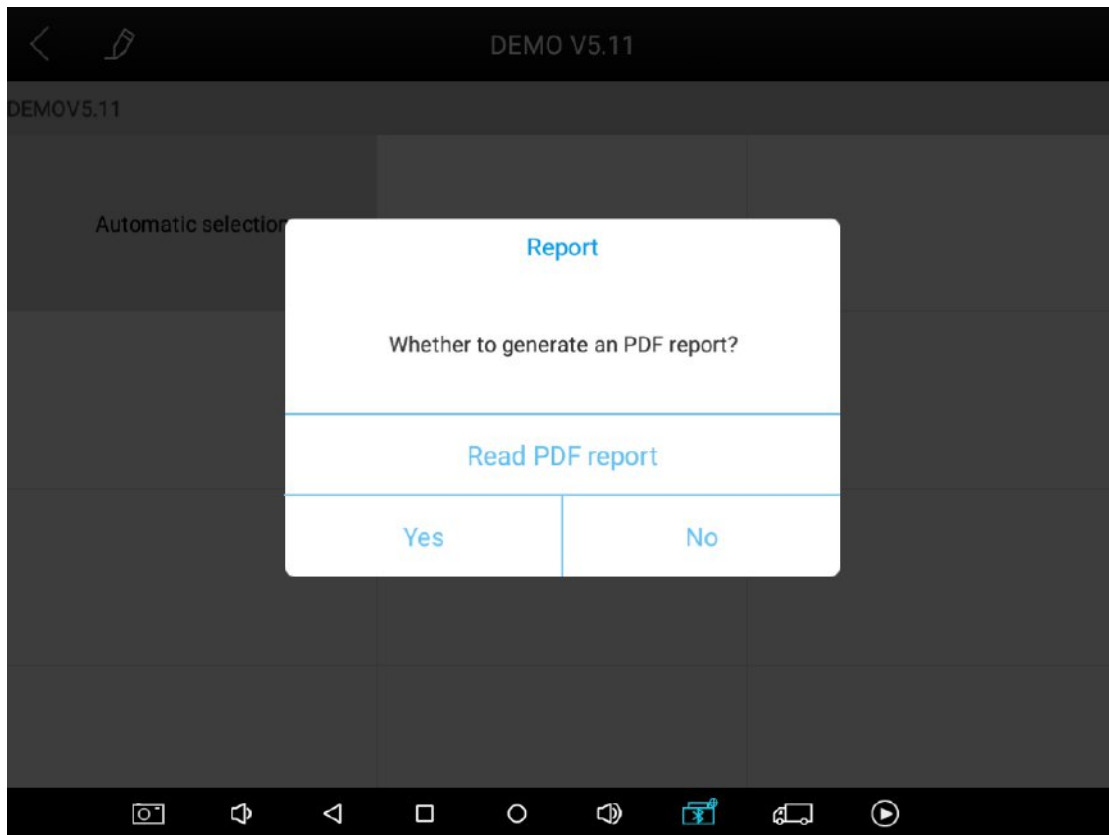

(Generate PDF report)

## 4.4. Update

This function is used to get the latest version software. Xtool will solve the software problem, or add new functions by update. When there is a new version software is released, there will be a notice to remind user. We strongly recommend user to update it.

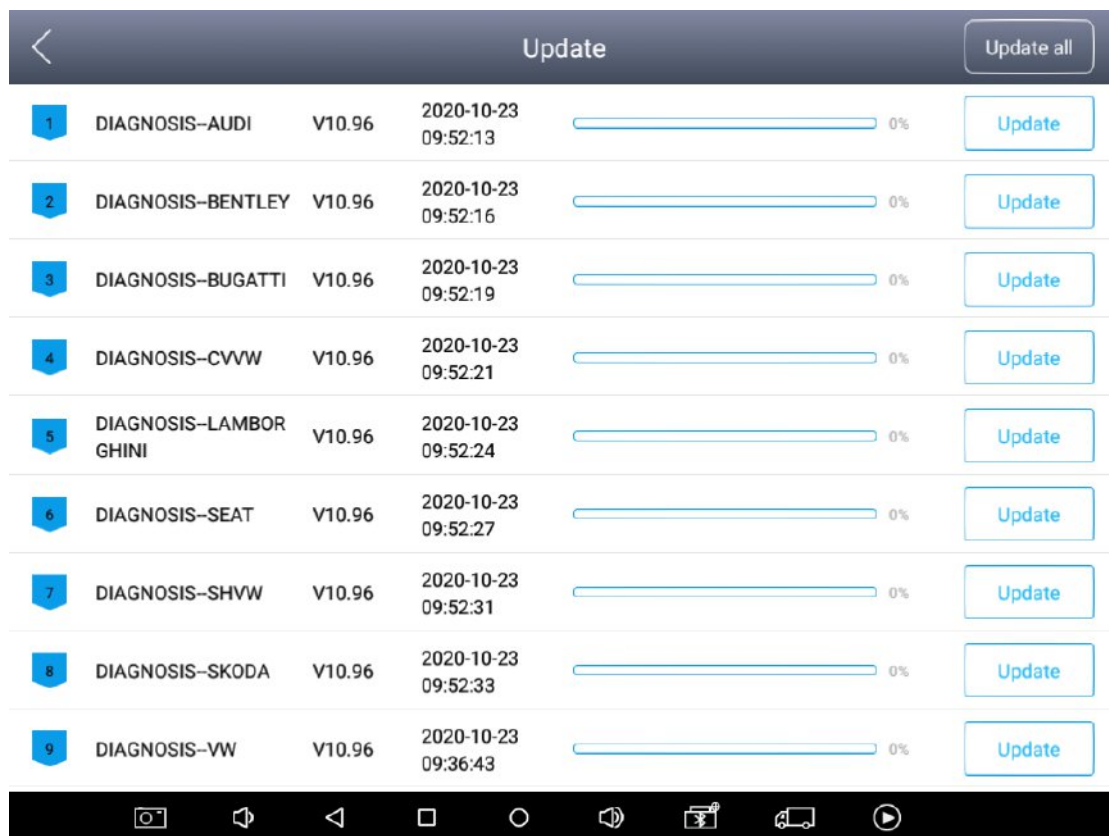

( [ Update ] )

## 4.5. Report

This function allows user to check and view saved files, including diagnostic reports, data playback, and file management.

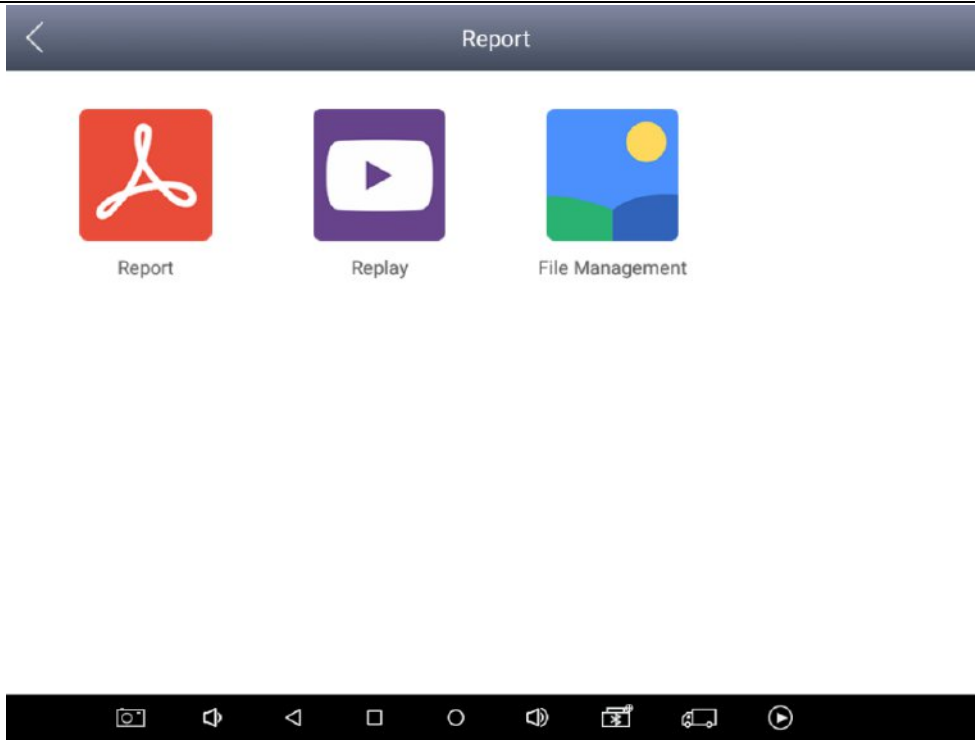

(Report main interface)

### Print

This function allows user to connect with printer wireless and print the report. During diagnosis, there will be a  icon on the screen as a indication.

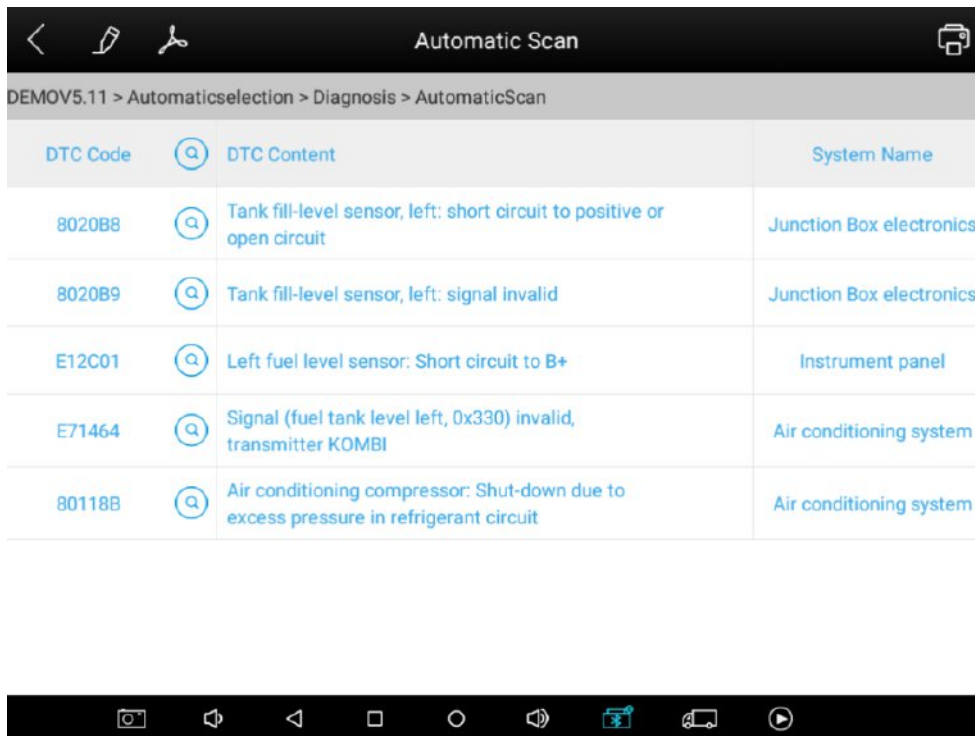

(Print interface)

## Report

This function allows user to view diagnostic reports.



(Report interface)

# Report sample

The screenshot shows a PDF viewer displaying a diagnostic report. Annotations with arrows point to specific parts of the report:

- User information:** Points to a box containing contact details: Tel.: +86075521670995, Email: Marketing@xtooltech.com.
- Diagnosis time and vehicle information:** Points to a box containing: Time: 2020-10-27 11:26:48, System: DEMO V5.11 -> Main menu -> Diagnostic menu.
- Diagnosis details:** Points to the 'Automatic Scan' table.

The report title is "Report" with SN: 123456.

Automatic Scan			
No.	ID	DTC Info	Status
1	DTC Code	DTC Content	System Name
2	8020B8	Tank fill-level sensor, left: short circuit to positive or open circuit	Junction Box electronics
3	8020B9	Tank fill-level sensor, left: signal invalid	Junction Box electronics
4	8020B8	Tank fill-level sensor, left: short circuit to positive or open circuit	Junction Box electronics
5	8020B9	Tank fill-level sensor, left: signal invalid	Junction Box electronics
6	E12C01	Left fuel level sensor: Short circuit to B+	Instrument panel

At the bottom of the screen, there is a navigation bar with icons for back, forward, search, and other functions.

## Replay

The Replay function allows user to view the live data record after using the live data function for diagnosis.

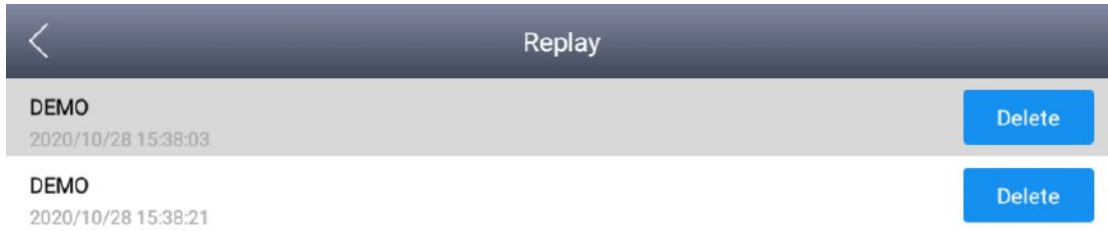

(Replay)

## File Management

This function allows user to manage the tablet storage. User can use it to delete the useless files on tablet to free up tablet space.

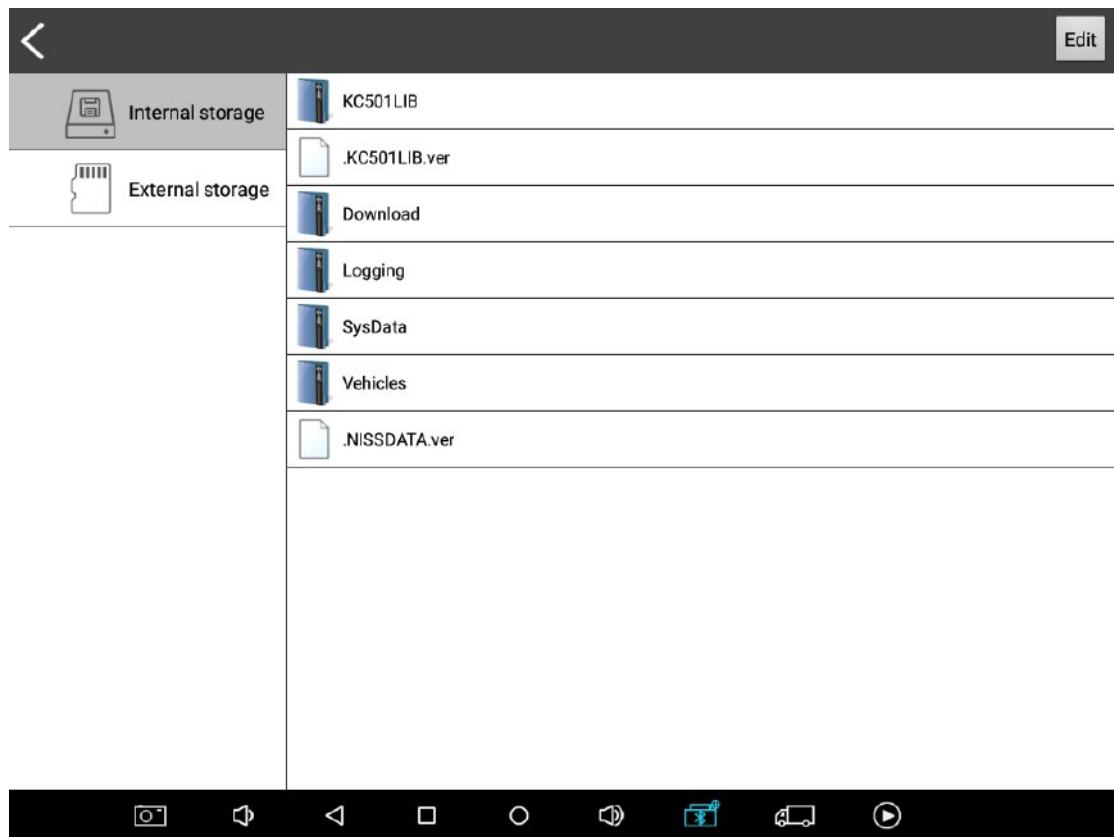

(File menu)

## 4.6. Xcloud

The Xcloud function is linked to Xtool official website support sector. User can watch the tutorial video, get latest update information, and download related upgrade tool. We strongly recommend user to visit Xtool website regularly to get the latest product and training information.

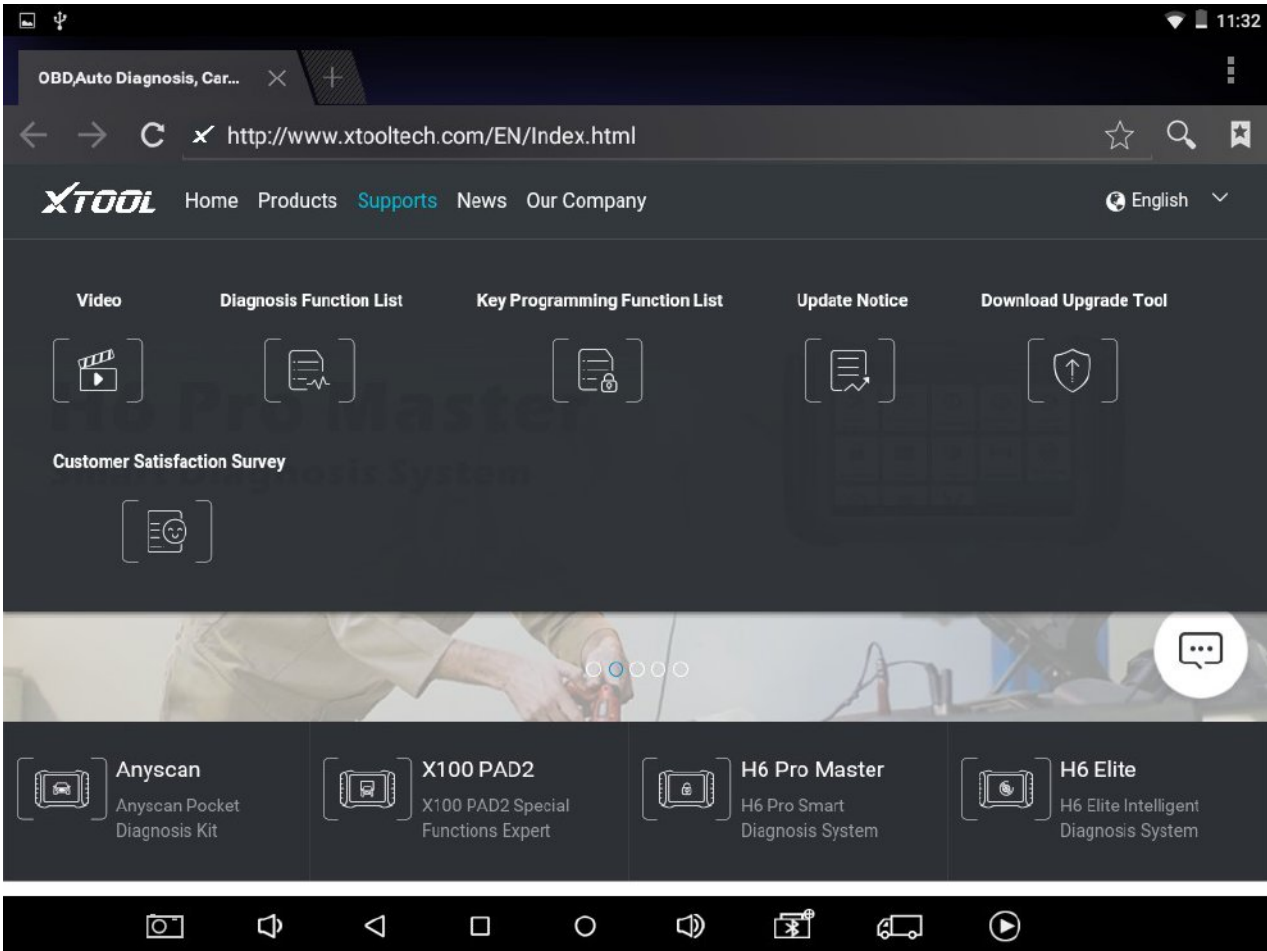

( [ Xcloud ] )



## 4.7. Remote

The remote function is linked to the TeamViewer QuickSupport application, which user can use it to get the remote control from technical support team of Xtool technician, engineer, or distributor. The technical support team will use their PC via TeamViewer software to control the H6 tablet under the permission of user.

Note: make sure H6 Pro Tablet is connected to internet, send the ID the the remote operator, and accept the remote control request on your device.

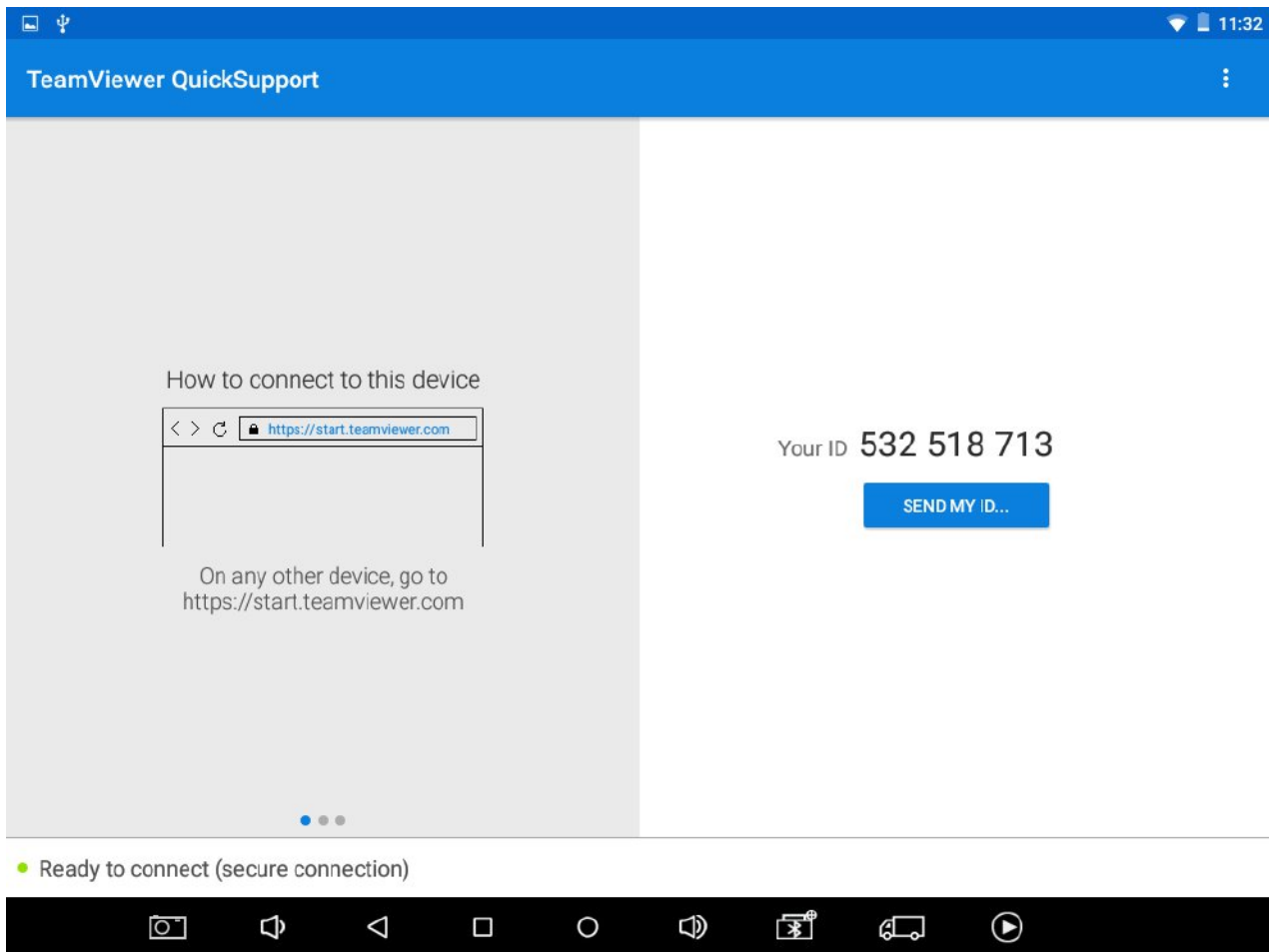

( [ Remote ] )

Remote control Steps:

1. Turn on the tablet, enter the Xtool diagnosis App
2. Click [Remote] to generate and display the device ID
3. Send the device ID to technical support staff
4. Agree the request from technical support to get the remote control

## 5. Support and service

This section provides Xtool support and service information. If user has any problems, or difficulties in using our products, please contact with us .We will try our best to help users solve problems.

### 5.1. Technical support

To better support customer, Xtool H6 series product has already added remote control function. When customer encounters problem, Xtool engineer can built communication with product through internet, and provides quick technical support and service. For detail information, please refer to [ **4.7 Remote** ]

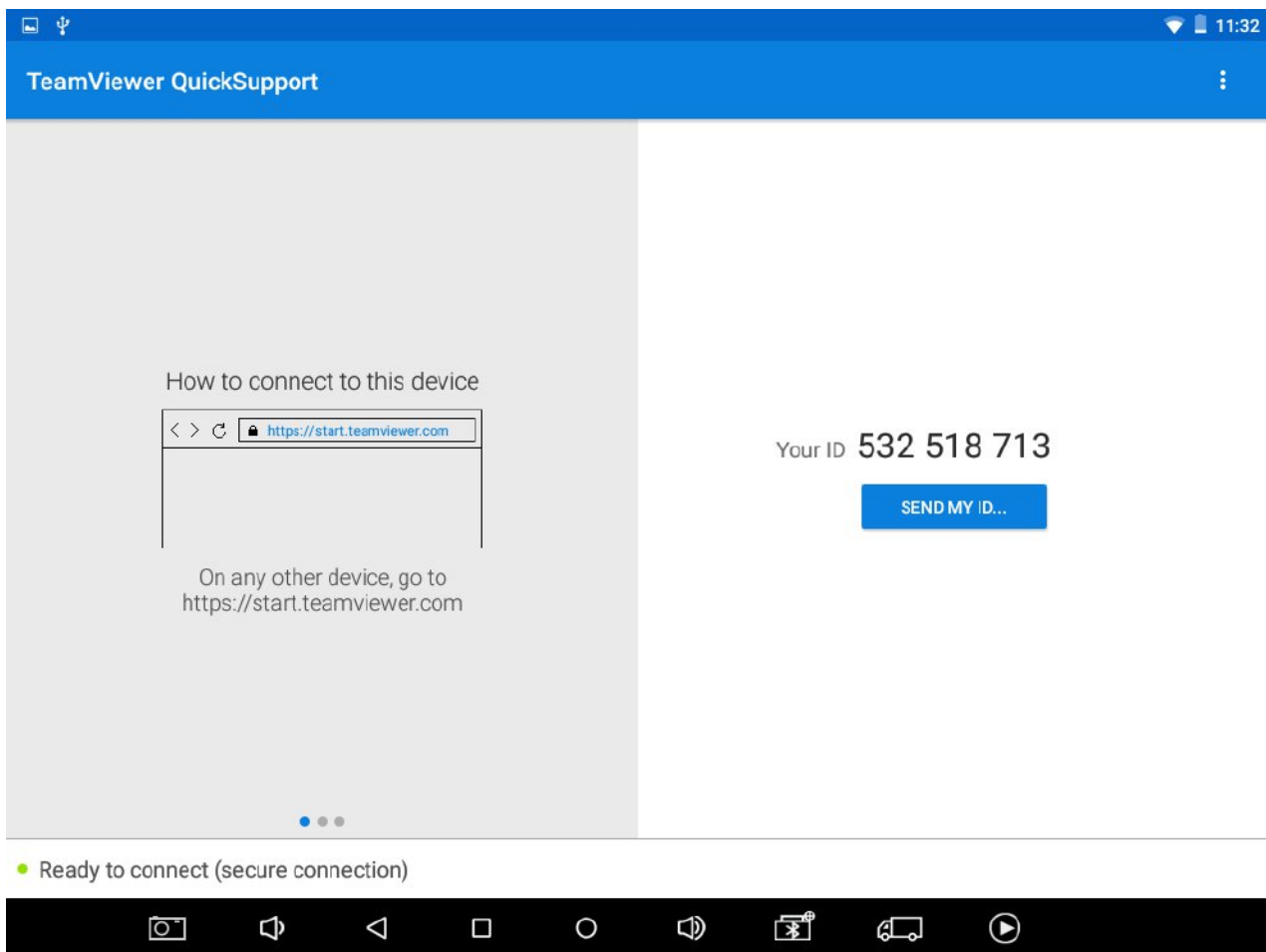

Xtool official website also provides tutorial video, update notice, update tool, and other useful information to customers. We strongly recommend customer to visit the website regularly to get the latest product support information.

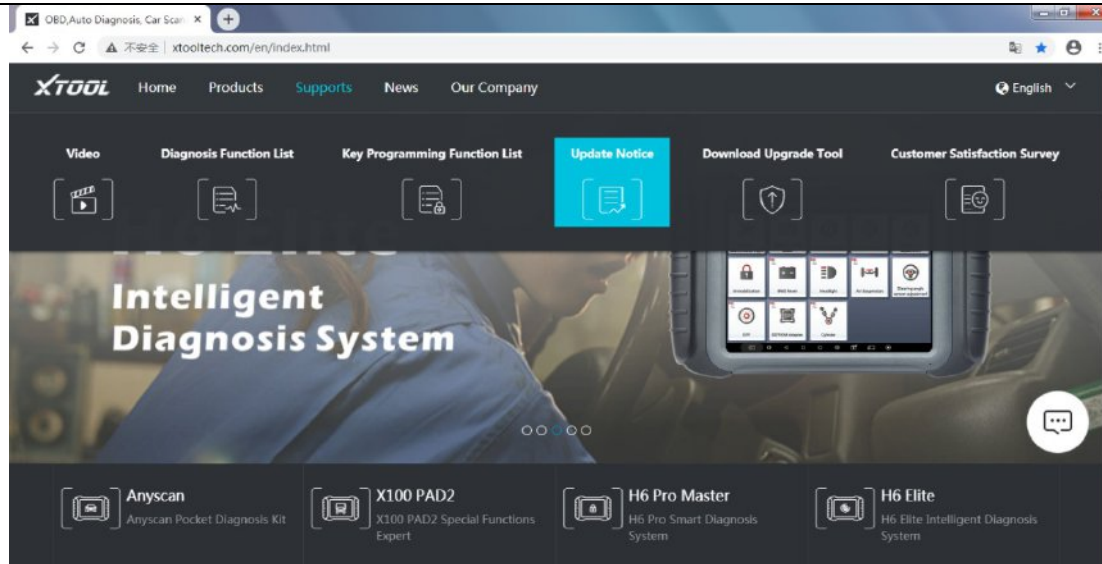

## 5.2. Service

If it is necessary to return the device to Xtool for repair, please confirm with Xtool first. The following information should be provided for further communication.

- Contact name / address
- Telephone number
- Product name, model, and SN
- Description of the problem
- Warranty information
- Other necessary information

## 5.3. FAQ

- When tablet cannot be turned on:
  - 1) Check the power source used to charge tablet works normally.
  - 2) Check the tablet charger connection to make sure the battery on it is charged properly.
- When the tablet cannot work normally:
  - 1) Make sure the tablet is connected to the Internet.
  - 2) Check registration statues to make sure that tablet is still in valid period.
  - 3) Check all of the cables, connectors, and indicators to see if the connection is

good.

- 4) Check the system software version, and update diagnostic application if necessarily.
  - When tablet duration time is shorter than usual:
    - 1) It may happen when tablet is used in an area with bad signal. Turn off the tablet when it is not in use.
  - When tablet cannot be charged
    - 1) The charger may has malfunction, and try to charge the tablet with another authorized charger
    - 2) Check the connector to make sure the tablet and power source are connected properly.
    - 3) Charge the tablet in appropriate ambient temperature, it cannot be charged under an overly hot/cold temperature condition.

## 6. Warranty

The Product Warranty applies only when Product is maintained in accordance with Xtool instructions, and the Product is properly installed. This warranty is only to the original purchaser of the Product(s) from Xtooltech, or authorized dealer, is not transferable and is further subject to the terms and conditions set forth herein.

Except where prohibited by law, XTOOLTECH will not be liable for any indirect, special, incidental or consequential damages, regardless of the legal theory asserted.

### **This Product Warranty does not cover:**

- Product with abnormal use, mishandling, exposed to extreme environmental conditions, accident,
- Product warranty label, or serial number has been removed, altered or defaced;
- Product with unauthorized alteration, improper installation or repair;
- Damage caused by connecting or using any other third party accessory or other product without approving of Xtool;
- Damage caused by external factors, such as fire, dirt, sand, water, snow, or unstable power source.

## Contact

### **Shenzhen Xtooltech Co., Ltd**

Company address: 2nd Floor, Building No.2, Block 1, Excellence City, No.128, Zhongkang Road, Shangmeilin, Futian District, Shenzhen, China

Factory address: 2/F, Building 12, Tangtou Third Industrial Zone, Shiyan Street, Baoan District, Shenzhen, China

Service Hotline: 400-880-3086/ 0755-21670995

Email: [marketing@xtooltech.com](mailto:marketing@xtooltech.com)

Fax: 0755-83461644

Website: [www.xtooltech.com](http://www.xtooltech.com)